

OPERATOR'S MANUAL

TP0844S5XXXXXXX

INCLUDING: OPERATION, INSTALLATION AND MAINTENANCE.

INCLUDE MANUALS: AF0844SXXXXX-XX-X Extrusion Pump (pn 97999-1519), 66516-X Follower Assembly (pn 97999-854), 67195-X Follower Assembly (pn 97999-841), 6751X-X Follower Assembly (pn 97999-1787), RM552X-XXX-XX Two Post Lift / Ram (pn 97999-1445), 651730 Air Manifold (pn 97999-626) and S-636 General Information (pn 97999-636).

RELEASED: 4-24-10

REVISED: 5-26-17

(REV: D)

8" AIR MOTOR
44:1 RATIO
6" STROKE

TWO POST RAM PACKAGE

55 Gallon



READ THIS MANUAL CAREFULLY BEFORE INSTALLING, OPERATING OR SERVICING THIS EQUIPMENT.

It is the responsibility of the employer to place this information in the hands of the operator. Keep for future reference.

SERVICE KITS

637489 for repair of AF06XX-XX air motor

104302 for repair of P39124-120 filter / regulator.

104453 for repair of P39344-110 filter / regulator.

637466 for repair of lift / ram seals.

637071-XXD-B for repair of 66243-XXD-B lower pump section.

MODEL DESCRIPTION CHART

TP 08 44 S 5 XXXXX XX X	
Package TP - Two Post	
Air Motor Size 08 - 8"	
Pump Ratio 44 - 44:1	
Check Type / Wetted Materials S - Chop Check / Carbon Steel	
Mount Style 5 - 55 gallon (400 lbs)	
Lower Pump End Options Refer to pump model operator's manual	
Follower Assembly	
AA - 66516-1 AV - 67195-3 AH - 67516-8	
AC - 66516 TM - 67195-5 AJ - 67516-3	
AB - 66516-2 TN - 67195-6 TE - 67516-5	
TC - 66516-5 TV - 67195-7 TF - 67516-6	
TA - 66516-6 AS - 67195-8 TH - 67516-9	
TB - 66516-7 TS - 67195-9 TJ - 67516-7	
AM - 67195-1 AE - 67516-1	
AN - 67195-2 AF - 67516-2	
Package Option	
0 - None- Basic Control for Ram only	
2 - Advanced Ram and Pump Controls	

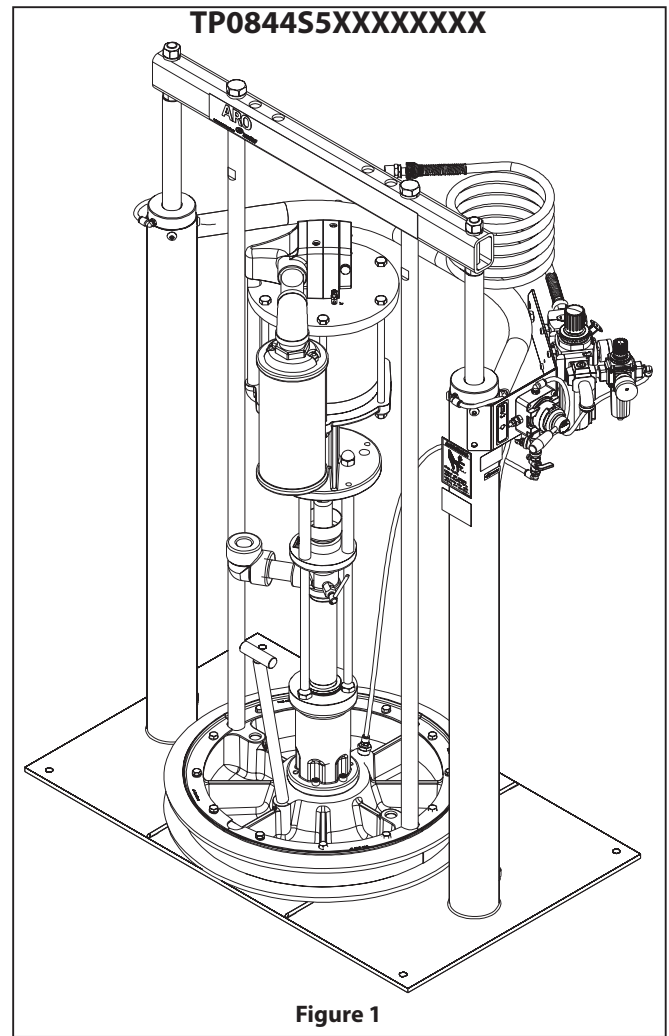

GENERAL DESCRIPTION

By delivering a smooth, continuous bead of the proper size, an ARO® system helps the operator maintain both production rate and produce high quality standards. Maintained quality standards assures that the material benefits are realized.

To further maximize operator production time, the ARO system has a built-in lift / ram feature for quick and easy drum changeover and easy lifting of the pump assembly from the container.

ARO systems are totally enclosed, sealing the material in the system from air and moisture, preventing premature cure-out of the material. This allows for either continuous or intermittent use of the system and allows the need for daily system clean-up.

INSTALLATION

The TP0844S5XXXXXXX Ram System comes completely assembled. Remove the unit from the crate and place on a level surface. Install the material hose and dispensing device as required.

When the following instructions are observed, heavy paste materials can be pumped directly from their original drum without air inclusion or excessive waste. The follower plate creates an air tight seal as well as clean-wiping action in its progressive downward movement into the drum.

OPERATING INSTRUCTIONS

OPERATING INSTRUCTIONS / INITIAL SET-UP PROCEDURE

⚠ WARNING Stand clear when raising or lowering the lift. Read the warnings on page 3 of RM552X-XXX-XX Two Post Lift / Ram Operator's Manual.

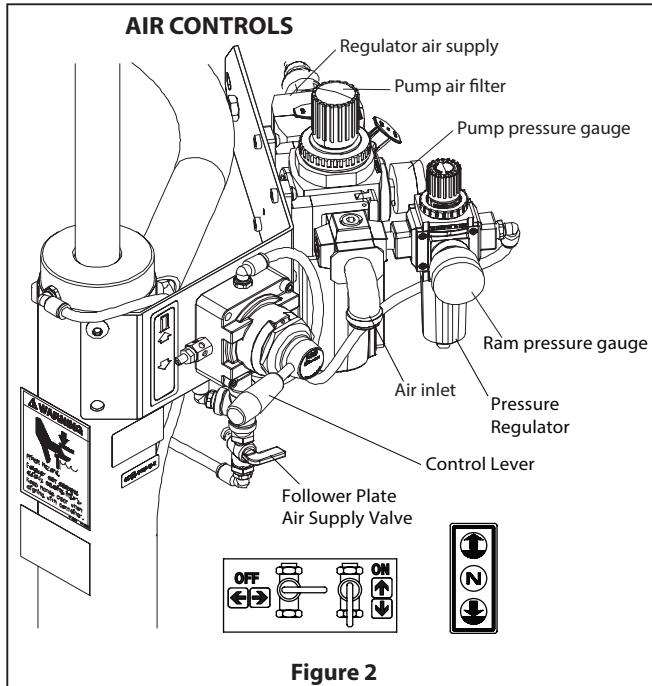

TO RAISE THE LIFT, (the first time):

1. Take note of the pump / drum clearance above. Be certain the lift / ram is clear of any objects above. Also, refer to "Operating and Safety Precautions" found on page 3 of RM552X-XXX-XX Two Post Lift / Ram Operator's Manual.
2. Connect the air supply (150 psig max.) to the air inlet. Adjust the air pressure on the lift / ram pressure regulator (turn the knob clockwise) to 20 psig (1.4 bar).
3. Shift the control valve lever to the "up" position.
4. Raise the lift / ram high enough to clear the height of the drum. Stop the lift upward travel by moving the control valve lever to the "neutral" (center) position.
5. Once the lift / ram assembly and pump are in the "up" position, place and center an opened drum of material on the lift / ram base.
6. Lubricate the lower follower wiper plate seal with grease. This ensures a smooth fit into the drum, as well as prevents curing type compounds from bonding to the seal.
NOTE: Make certain the grease is compatible with the material being dispensed.

7. Check the vent plug on the follower plate to be sure it easily threads in and out. It is recommended to lubricate the threads of the plug to help prevent possible set-up of the compound at this point (see RM552X-XXX-XX Operator's Manual).

TO LOWER LIFT:

⚠ WARNING PINCH HAZARD. Follower can descend quickly, causing injury. Keep hands clear when aligning with container. Read the warnings on page 3 of RM552X-XXX-XX Two Post Lift / Ram Operator's Manual.

NOTE: Be certain the follower plate vent plug has been removed so that the air trapped between the follower and the material is allowed to escape from this vent. Captured air between the follower plate and drum will escape.

NOTE: The lift / ram may hesitate momentarily before starting downward. The air pressure inside the post air chamber must decrease before it will begin to descend.

1. Shift the control valve lever to the "down" position and proceed to lower the pump.
2. Replace the vent plug once the material begins to ooze from the vent opening.
3. The unit is now ready for operation. Adjust the air pressure on the pump filter / regulator (turn the pump regulator knob clockwise) until the pump begins to cycle.
4. Trigger the gun to prime the pump with material.

TO RAISE LIFT, (normal operation):

1. Close the pump air supply valve.
2. Adjust the follower plate air valve pressure up to approximately 8 psig (0.55 bar). **DO NOT OVER PRESSURIZE THE DRUM** to avoid damage. **NOTE:** Air from this valve will only pass when the control lever is in the "up" position.
3. Shift the control valve lever to the "up" position.
4. Raise the lift / ram high enough to clear the height of the drum. Stop the lift upward travel by moving the control valve lever to the "neutral" (center) position.

TO CHANGE THE DRUM:

NOTE: The control valve lever must be in the "neutral" position.

1. To avoid damage, **DO NOT OVER PRESSURIZE THE DRUM.**
2. Open the follower plate supply valve to allow air under the follower plate.
3. Shift the control valve lever to the "up" position.
4. Remove the old drum.
5. Place and center a new drum into position.

PARTS LIST / TP0844S5XXXXXX

Item	Description (size)	Qty	Part No.
1	Muffler	(1)	94810
2	Pump Assembly	(1)	AF0844S1XXXXX-X
3	Nipple (1/4 NPT x 2" long)	(1)	Y44-65-C
4	Reducing Elbow	(1)	96297
5	Two-Post Lift / Ram	(1)	RM552X-XXX-XX
6	Elbow (1" - 11-1/2 NPTF)	(1)	Y43-316-C
7	Nipple (1" - 11-1/2 NPTF)	(1)	90818

Item	Description (size)	Qty	Part No.
8	Cap Screw	(1)	Y99-63-C
9	Follower Assembly (see model description chart on page 1)	(1)	
10	Connector (1/4 - 18 NPT x 5/16" o.d. tubing)	(1)	59474-158
11	Tubing (5/16" o.d. x 44")	(1)	94980-(①)
12	Wet-Sol "Plus" (1 quart) (not shown)	(1)	66333-B
①	Bulk Tubing (5/16" o.d. x 100')	(1)	94980-100

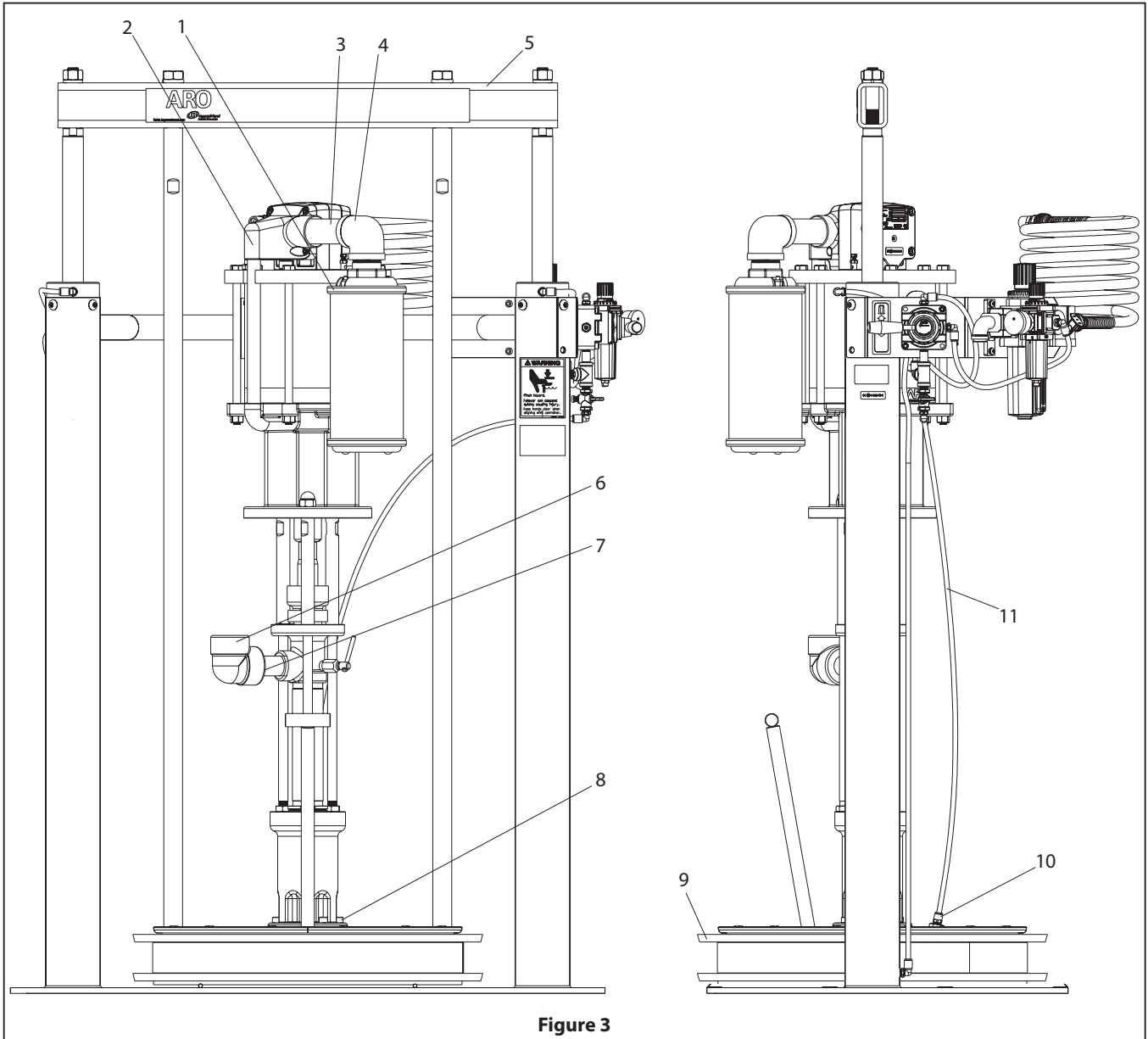

DIMENSIONAL DATA

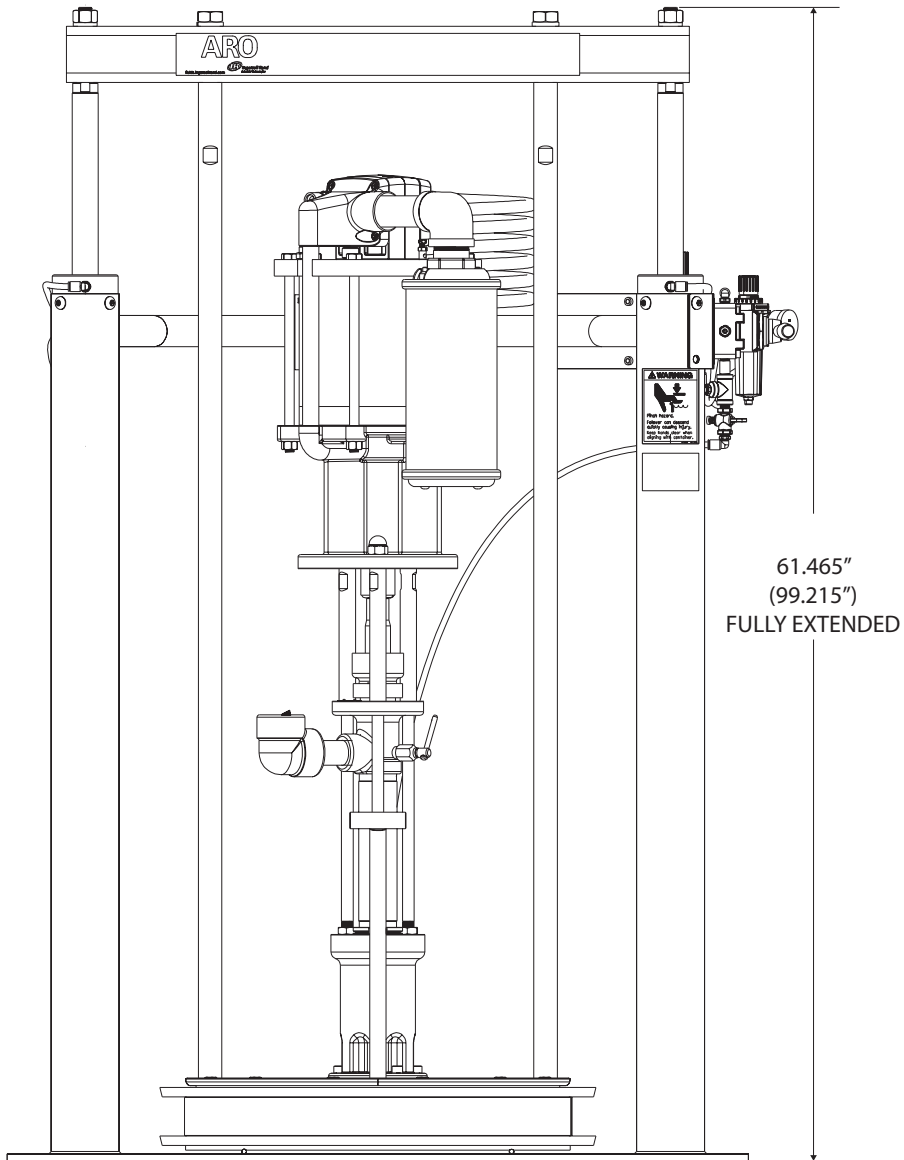
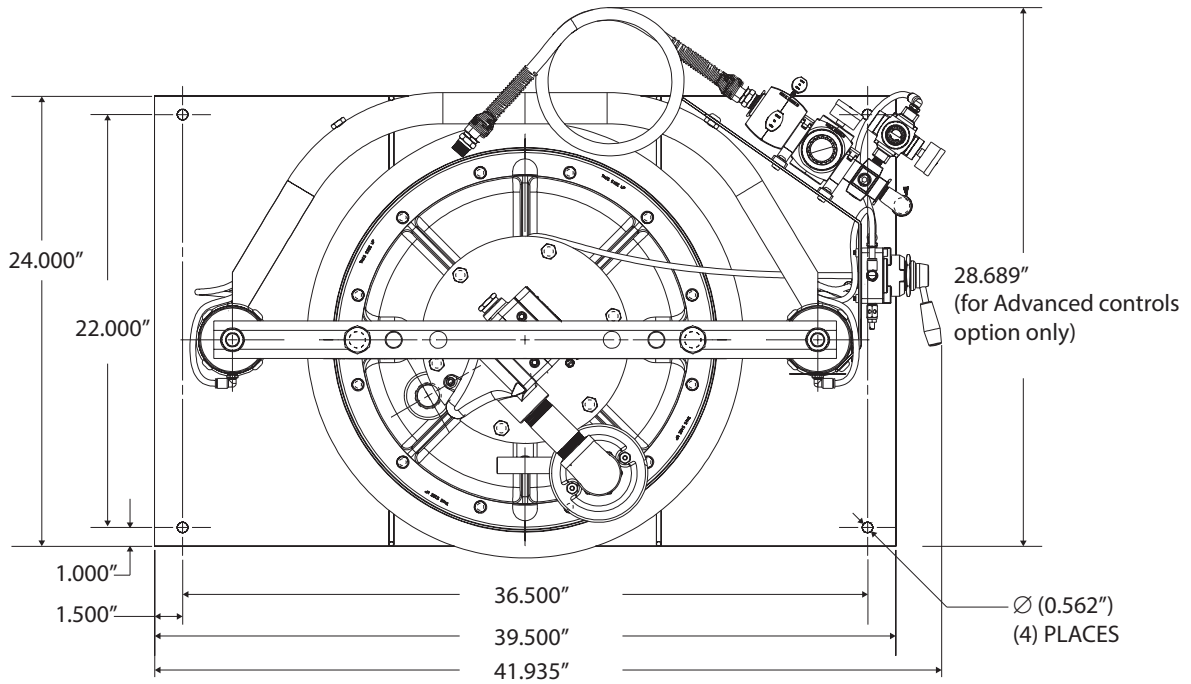

Figure 4