

ELECTRONIC INTERFACE

for Diaphragm Pumps

RELEASED: 3-26-13
 REVISED: 12-6-19
 (REV: J)



**READ THIS MANUAL CAREFULLY BEFORE INSTALLING,
 OPERATING OR SERVICING THIS EQUIPMENT.**

It is the responsibility of the employer to place this information in the hands of the operator. Keep for future reference.

PUMP DATA

PE10X-XXX-XXX-XXXX is PE series 1" EXP Diaphragm Pumps with electronic interface.

PE15X-XXX-XXX-XXXX is PE series 1- 1/2" EXP Diaphragm Pumps with electronic interface.

PE20X-XXX-XXX-XXXX is PE series 2" EXP Diaphragm Pumps with electronic interface.

PE30X-XXX-XXX-XXXX is PE series 3" EXP Diaphragm Pumps with electronic interface.

GENERAL DESCRIPTION

This manual is supplemental information for the electronic interface options on the PE series of pumps. For complete pump installation, disassembly and reassembly, safety information, and other general pump information, please refer to the PD pump manual that was also included with the pump.

This electronic interface includes options for solenoid control, end of stroke feedback, leak detection (diaphragm failure), cycle counting on the major valve, and a ported motor with no major valve for user-supplied control directly to the two diaphragm air chambers.

Solenoid control allows the cycle rate of the pump to be controlled electronically.

With Solenoid control, when the solenoid is energized, the pump strokes and dispenses the fluid in one chamber. When the solenoid is de-energized, the pump strokes in the opposite direction, dispensing the fluid in the other chamber.

By providing continuous ON - OFF signals to the solenoid, the fluid transfer rate may be increased or decreased remotely.

End of stroke feedback can be used in conjunction with the solenoid valve to cycle the pump based upon completion of each stroke.

The leak detection option incorporates an optical fluid sensor in each air chamber to provide a signal when a diaphragm has failed and fluid is leaking through the pump.

The ported motor with no major valve is provided as an option for users who want to supply compressed air directly to each diaphragm and control the operation of the pump with their own external air controls.

MODEL DESCRIPTION CHART

PEXX X-XXX-XXX-XX XX	
Pump Size	10 - 1" EXP Diaphragm Pumps (★) 15 - 1- 1/2" EXP Diaphragm Pumps (★) 20 - 2" EXP Diaphragm Pumps (★) 30 - 3" EXP Diaphragm Pumps (★)
Center Section	A - Aluminium S - Stainless P, R - Polypropylene E, F, Y - Conductive poly
Fluid Caps & Manifold Material	A - Aluminum (★) C - Cast Iron (★) D - Conductive Polypropylene (single port) (★) E - Conductive Polypropylene (multiple port) (★) H - Hasteloy (★) K - PVDF (Kynar®) (single port) L - PVDF (Kynar®) (multiple port) N - Conductive PVDF P - Polypropylene (single port) R - Polypropylene (multiple port) S - Stainless Steel (★)
Revision Level	
Specialty Code 1 (Blank if no Specialty Code)	A - Solenoid 120 VAC B - Solenoid 12 VDC C - Solenoid 240 VAC D - Solenoid 24 VDC E - Solenoid 12 VDC NEC / CEC (★) F - Solenoid 24 VDC NEC / CEC (★) G - Solenoid 12 VDC ATEX / IECEx (★) H - Solenoid 24 VDC ATEX / IECEx (★) J - Solenoid 120 VAC NEC / CEC (★) K - Solenoid 220 VAC ATEX / IECEx (★) N - Solenoid with no coil (★) P - Ported Motor (No major valve provided) (★) 0 - Standard Valve Block (No Solenoid) (★)
Specialty Code 2 (Blank if no Specialty Code)	E - End of Stroke Feedback + Leak Detection F - End of Stroke Feedback G - End of Stroke ATEX / IECEx (★) H - End of Stroke + Leak Detection ATEX / IECEx (★) L - Leak Detection M - Leak Detection ATEX / IECEx / NEC / CEC (★) R - End of Stroke Feedback NEC / CEC (★) T - End of Stroke Feedback + Leak Detection NEC / CEC (★) 0 - No Option
Special Testing	Testing for special testing options, please contact your nearest ARO Customer Service Representative or Distributor.

(★) Only options indicated with an asterisk (★) are acceptable for use in hazardous locations, however, certain combinations are not possible.

SOLENOID VALVE BLOCK SERVICE KIT OPTIONS

1" Solenoid Valve Block Service Kit 637541 - X - X

Valve Block Materials

- 1 - Aluminum
- 2 - Stainless Steel
- 3 - Black Non-Metallic
- 4 - White Non-Metallic

For Solenoid Option, choose letter in Specialty Code 1 from "MODEL DESCRIPTION CHART"

Includes items: 105, 111, 128, 132, 135, 136, 137, 138, 139, 140, 141, 166, 200, 233, 403, 413, 414, 415, 416, 417, 418, 419, 420, 421 and 429

2" and 3" Solenoid Valve Block Service Kit 637543 - X - X

Valve Block Materials

- 1 - Aluminum
- 2 - Stainless Steel
- 3 - Black Non-Metallic
- 4 - White Non-Metallic

For Solenoid Option, choose letter in Specialty Code 1 from "MODEL DESCRIPTION CHART"

Includes items: 105, 111, 128, 132, 135, 136, 137, 138, 139, 140, 141, (146, 147) 166, 199, 200, 232, 240, 241, 242, 243, 403, 413, 414, 415, 416, 417, 418, 419, 420, 421 and 429

1 1/2" Solenoid Valve Block Service Kit 637542 - X - X

Valve Block Materials

- 1 - Aluminum
- 2 - Stainless Steel
- 3 - Black Non-Metallic

For Solenoid Option, choose letter in Specialty Code 1 from "MODEL DESCRIPTION CHART"

Includes items: 105, 111, 128, 132, 135, 136, 137, 138, 139, 140, 141, 166, 200, 233, 403, 413, 414, 415, 416, 417, 418, 419, 420, 421 and 429

PARTS LIST / ALUMINUM CENTER BODY

Item	Description	Part no.	Qty
101	Centerbody (PE10A and PE15A)	97025	(1)
	(PE20A and PE30A)	97031	(1)
111	Spool (PE10A-XXX-XXX-X0XX, PE15A-XXX-XXX-X0XX)	95835	(1)
	All PE10A, PE15A with Solenoid	95835-2	(1)
	(PE20A-XXX-XXX-X0XX, PE30A-XXX-XXX-X0XX)	95651	(1)
	All PE20A, PE30A with Solenoid	95651-2	(1)
121	Sleeve (PE10A-XXX-XXX-XPXX, PE15A-XXX-XXX-XPXX)	96323	(2)
	(PE20A-XXX-XXX-XPXX, PE30A-XXX-XXX-XPXX)	96613	(2)
134	Screw (PE10A-XXX-XXX-XPXX, PE15A-XXX-XXX-XPXX)	96340	(4)
	(PE20A-XXX-XXX-XPXX, PE30A-XXX-XXX-XPXX)	95923	(4)
135	Valve Block (PE10A-XXX-XXX-X0XX)	95942-3	(1)
	(PE15A-XXX-XXX-X0XX)	95942-1	(1)
	All PE10A with Solenoid	95942-6	(1)
	All PE15A with Solenoid	95942-5	(1)
	(PE20A-XXX-XXX-X0XX, PE30A-XXX-XXX-X0XX)	96334-1	(1)
	All PE20A, PE30A with Solenoid	96334-3	(1)
403	Valve (All PEXXA with Solenoid)	114102	(1)
407	Carrot Plug (PE10/15)	96316	(1)
	(PE20/30)	96317	(1)
411	Adapter (PEXXA-XXX-XXX-XAXX, PEXXA-XXX-XXX-XBXX, PEXXA-XXX-XXX-XCXX, PEXXA-XXX-XXX-XDXX, PEXXA-XXX-XXX-XEXX, PEXXA-XXX-XXX-XFXX, PEXXA-XXX-XXX-XGXX, PEXXA-XXX-XXX-XHXX, PEXXA-XXX-XXX-XJXX, PEXXA-XXX-XXX-XKXX, PEXXA-XXX-XXX-XLXX)	96953	(1)
413	Coil Nut (All PEXXA with Solenoid)	119380	(1)

Item	Description	Part no.	Qty	
414	Coil, 120VAC (PXXXX-XXX-XXX-XAXX)	116218-33	(1)	
	Coil, 12VDC (PXXXX-XXX-XXX-XBXX)	116218-38	(1)	
	Coil, 240VAC (PXXXX-XXX-XXX-XCXX)	116218-35	(1)	
	Coil, 24VDC (PXXXX-XXX-XXX-XDXX)	116218-39	(1)	
	Coil, 12VDC ATEX / IECEx (PXXXX-XXX-XXX-XGXX)	117345-38	(1)	
	Coil, 24VDC ATEX / IECEx (PXXXX-XXX-XXX-XHXX)	117345-39	(1)	
	Coil, 220VAC ATEX / IECEx (PXXXX-XXX-XXX-XKXX)	117345-35	(1)	
	Coil, 12VDC NEC/CEC (PXXXX-XXX-XXX-XEXX)	114772-38	(1)	
	Coil, 24VDC NEC/CEC (PXXXX-XXX-XXX-XFXX)	114772-39	(1)	
	Coil, 120VDC NEC/CEC (PXXXX-XXX-XXX-XJXX)	114772-33	(1)	
	415	O-Ring (All PEXXA with Solenoid)	114103	(1)
	416	O-Ring (All PEXXA with Solenoid)	114104	(1)
	417	Screw (All PEXXA with Solenoid)	96728647	(2)
	418	Tube (All PEXXA with Solenoid)	15309974	(1)
419	Seal (All PEXXA with Solenoid)	96957	(1)	
420	Snap Ring (All PEXXA with Solenoid)	Y147-43	(1)	
421	Retainer (All PEXXA with Solenoid)	15309990	(1)	
428	O-Ring (All PEXXA with Solenoid)	Y325-13	(1)	
429	Solenoid Muffler (All PEXXA with Solenoid)	116464	(1)	

PARTS LIST / STAINLESS STEEL CENTER BODY

Item	Description	Part no.	Qty	Item	Description	Part no.	Qty	
101	Centerbody (PE10S and PE15S)	97034	(1)	414	Coil, 120VAC (PXXXX-XXX-XXX-XAXX)	116218-33	(1)	
	(PE20S and PE30S)	97040	(1)		Coil, 12VDC (PXXXX-XXX-XXX-XBXX)	116218-38	(1)	
111	Spool (PE10S-XXX-XXX-XQXX, PE15S-XXX-XXX-XQXX)	95835	(1)		Coil, 240VAC (PXXXX-XXX-XXX-XCXX)	116218-35	(1)	
	All PE10S, PE15S with Solenoid	95835-2	(1)		Coil, 24VDC (PXXXX-XXX-XXX-XDXX)	116218-39	(1)	
	(PE20S-XXX-XXX-XQXX, PE30S-XXX-XXX-XQXX)	95651	(1)		Coil, 12VDC ATEX / IECEx (PXXXX-XXX-XXX-XGXX)	117345-38	(1)	
	All PE20S, PE30S with Solenoid	95651-2	(1)		Coil, 24VDC ATEX / IECEx (PXXXX-XXX-XXX-XHXX)	117345-39	(1)	
121	Sleeve (PE10S-XXX-XXX-XPXX, PE15S-XXX-XXX-XPXX)	96323	(2)		Coil, 220VAC ATEX / IECEx (PXXXX-XXX-XXX-XKXX)	117345-35	(1)	
	(PE20S-XXX-XXX-XPXX, PE30S-XXX-XXX-XPXX)	96613	(2)		Coil, 12VDC NEC / CEC (PXXXX-XXX-XXX-XEXX)	114772-38	(1)	
134	Screw (PE10S-XXX-XXX-XPXX, PE15S-XXX-XXX-XPXX)	96340	(4)		Coil, 24VDC NEC / CEC (PXXXX-XXX-XXX-XFXX)	144772-39	(1)	
	(PE20S-XXX-XXX-XPXX, PE30S-XXX-XXX-XPXX)	95923	(4)		Coil, 120VAC NEC / CEC (PXXXX-XXX-XXX-XJXX)	144772-33	(1)	
135	Valve Block (PE10S-XXX-XXX-XQXX)	95939-3	(1)		415	O-Ring (All PEXXS with Solenoid)	114103	(1)
	(PE15S-XXX-XXX-XQXX)	95939-1	(1)		416	O-Ring (All PEXXS with Solenoid)	114104	(1)
	All PE10S with Solenoid	95939-6	(1)		417	Screw (All PEXXS with Solenoid)	96728647	(2)
	All PE15S with Solenoid	95939-5	(1)		418	Tube (All PEXXS with Solenoid)	15309974	(1)
	(PE20S-XXX-XXX-XQXX, PE30S-XXX-XXX-XQXX)	96337-1	(1)	419	Seal (All PEXXS with Solenoid)	96957	(1)	
	All PE20S, PE30S with Solenoid	96337-3	(1)	420	Snap Ring (All PEXXS with Solenoid)	Y147-43	(1)	
403	Valve (All PEXXS with Solenoid)	114102	(1)	421	Retainer (All PEXXS with Solenoid)	15309990	(1)	
407	Carrot Plug (PE10/15)	96316	(1)	428	O-Ring (All PEXXS with Solenoid)	Y325-13	(1)	
	(PE20/30)	96317	(1)	429	Solenoid Muffler (All PEXXS with Solenoid)	116464	(1)	
411	Adapter (PEXXS-XXX-XXX-XAXX, PEXXS-XXX-XXX-XBXX, PEXXS-XXX-XXX-XCXX, PEXXS-XXX-XXX-XDXX, PEXXS-XXX-XXX-XEXX, PEXXS-XXX-XXX-XFXX, PEXXS-XXX-XXX-XGXX, PEXXS-XXX-XXX-XHXX, PEXXS-XXX-XXX-XJXX, PEXXS-XXX-XXX-XKXX, PEXXS-XXX-XXX-XNXX)	96953	(1)					
	413	Coil Nut (All PEXXS with Solenoid)	119380	(1)				

PARTS LIST / PLASTIC CENTER BODY

Item	Description	Part no.	Qty
101	Centerbody (PE10P and PE15P) and (PE10R and PE15R)	97026	(1)
	(PE10E and PE15E) and (PE10F and PE15F)	97032	(1)
	(PE20P, PE 20R and PE30R, PE20Y)	97037	(1)
	(PE20E, PE20F and PE30F)	97044	(1)
111	Spool (PE10E-XXX-XXX-X0XX, PE15E-XXX-XXX-X0XX, PE10F-XXX-XXX-X0XX, PE15F-XXX-XXX-X0XX, PE10P-XXX-XXX-X0XX, PE15P-XXX-XXX-X0XX, PE10R-XXX-XXX-X0XX, PE15R-XXX-XXX-X0XX)	96293	(1)
	All PE10E, PE10F, PE10P, PE10R, PE15E, PE15F, PE15P and PE15R with solenoid	96293-2	(1)
	(PE20E-XXX-XXX-X0XX, PE20F-XXX-XXX-X0XX, PE20P-XXX-XXX-X0XX, PE20R-XXX-XXX-X0XX, PE20Y-XXX-XXX-X0XX, PE30F-XXX-XXX-X0XX, PE30R-XXX-XXX-X0XX)	95651	(1)
	All PE20E, PE20F, PE20P, PE20R, PE20Y, PE30F and PE30R with solenoid	95651-2	(1)
121	Sleeve (PE10X-XXX-XXX-XPXX, PE15X-XXX-XXX-XPXX)	96323	(2)
	(PE20X-XXX-XXX-XPXX, PE30X-XXX-XXX-XPXX)	96613	(2)
134	Screw (PE10X-XXX-XXX-XPXX, PE15X-XXX-XXX-XPXX)	96340	(6)
	(PE20X-XXX-XXX-XPXX, PE30X-XXX-XXX-XPXX)	95323	(4)
135	Valve Block (PE10E-XXX-XXX-X0XX, PE10F-XXX-XXX-X0XX)	96174-3	(1)
	(PE10P-XXX-XXX-X0XX, PE10R-XXX-XXX-X0XX)	96174-1	(1)
	(PE15E-XXX-XXX-X0XX, PE15F-XXX-XXX-X0XX)	95834-5	(1)
	(PE15P-XXX-XXX-X0XX, PE15R-XXX-XXX-X0XX)	95834-1	(1)
	All PE10E, PE10F with solenoid	96174-6	(1)
	All PE15E, PE15F with solenoid	95834-6	(1)
	All PE10P, PE10R with solenoid	96174-4	(1)
	All PE15P, PE15R with solenoid	95834-4	(1)
	(PE20P-XXX-XXX-X0XX, PE20R-XXX-XXX-X0XX, PE20Y-XXX-XXX-X0XX) (PE30R-XXX-XXX-X0XX)	95789	(1)
	(PE20E-XXX-XXX-X0XX, PE20F-XXX-XXX-X0XX, PE30F-XXX-XXX-X0XX)	95789-2	(1)
	All PE20P, PE20R, PE20Y and PE30R with solenoid	95789-3	(1)
	All PE20E, PE20F and PE30F with solenoid	95789-4	(1)
403	Valve (All PEXXR with Solenoid)	114102	(1)

Item	Description	Part no.	Qty	
407	Carrot Plug (PE10/15)	96316	(1)	
	(PE20/30)	96317	(1)	
411	Adapter (PEXXX-XXX-XXX-XAXX, PEXXX-XXX-XXX-XBXX, PEXXX-XXX-XXX-XCXX, PEXXX-XXX-XXX-XDXX, PEXXX-XXX-XXX-XEXX, PEXXX-XXX-XXX-XFXX, PEXXX-XXX-XXX-XGXX, PEXXX-XXX-XXX-XHXX, PEXXX-XXX-XXX-XJXX, PEXXX-XXX-XXX-XKXX, PEXXX-XXX-XXX-XNXX)	96953	(1)	
	Coil Nut (All PEXXR with Solenoid)	119380	(1)	
414	Coil, 120VAC (PXXXR-XXX-XXX-XAXX)	116218-33	(1)	
	Coil, 12VDC (PXXXX-XXX-XXX-XBXX)	116218-38	(1)	
	Coil, 240VAC (PXXXX-XXX-XXX-XCXX)	116218-35	(1)	
	Coil, 24VDC (PXXXX-XXX-XXX-XDXX)	116218-39	(1)	
	Coil, 12VDC ATEX / IECEx (PXXXX-XXX-XXX-XGXX)	117345-38	(1)	
	Coil, 24VDC ATEX / IECEx (PXXXX-XXX-XXX-XHXX)	117345-39	(1)	
	Coil, 220VAC ATEX / IECEx (PXXXX-XXX-XXX-XKXX)	117345-35	(1)	
	Coil, 12VDC NEC / CEC (PXXXX-XXX-XXX-XEXX)	114772-38	(1)	
	Coil, 24VDC NEC / CEC (PXXXX-XXX-XXX-XFXX)	114772-39	(1)	
	Coil, 120VAC NEC / CEC (PXXXX-XXX-XXX-XJXX)	114772-33	(1)	
	415	O-Ring (All PEXXX with Solenoid)	114103	(1)
	416	O-Ring (All PEXXX with Solenoid)	114104	(1)
417	Screw (All PEXXX with Solenoid)	96728647	(2)	
418	Tube (All PEXXX with Solenoid)	15309974	(1)	
419	Seal (All PEXXX with Solenoid)	96957	(1)	
420	Snap Ring (All PEXXX with Solenoid)	Y147-43	(1)	
421	Retainer (All PEXXX with Solenoid)	15309990	(1)	
428	O-Ring (All PEXXX with Solenoid)	Y325-13	(1)	
429	Solenoid Muffler (All PEXXX with Solenoid)	116464	(1)	

PARTS LIST / PEXXX-XXX-XXX-XXXX

Item	Description	Part no.	Qty
1	Rod, Connecting (PE10)	97146	(1)
	(PE15)	97147	(1)
	(PE20)	97386	(1)
	(PE30)	97387	(1)
74	Pipe Plug (Not Shown) (PEXXA-XXX-XXX-XXFX, PEXXA-XXX-XXX-XXGX, PEXXA-XXX-XXX-XXGX) (PEXXF-XXX-XXX-XXFX, PEXXF-XXX-XXX-XXOX, PEXXF-XXX-XXX-XXGX) (PEXXR-XXX-XXX-XXFX, PEXXR-XXX-XXX-XXOX, PEXXR-XXX-XXX-XXGX) (PEXXS-XXX-XXX-XXFX, PEXXS-XXX-XXX-XXOX, PEXXS-XXX-XXX-XXGX) (PEXXY-XXX-XXX-XXFX, PEXXY-XXX-XXX-XXOX, PEXXY-XXX-XXX-XXGX) (PEXXE-XXX-XXX-XXFX, PEXXE-XXX-XXX-XXOX, PEXXE-XXX-XXX-XXGX) (PEXXP-XXX-XXX-XXFX, PEXXP-XXX-XXX-XXOX, PEXXP-XXX-XXX-XXGX)	Y17-51-S	(2)
		93832-3	(2)
		97391	(1)
		97392	(1)
103	Bushing (PE10)	97391	(1)
	(PE15)	97392	(1)
126	Plug (Stainless Steel)	Y17-13-S	(1)
	(Plastic)	93897-1	(1)
197	Leak Detector Sensor Adapter (PEXX-XXX-XXX-XXEX, PEXX-XXX-XXX-XXLX)	95088	(1)
198	Leak Detector Sensor Cable (PEXX-XXX-XXX-XXEX, PEXX-XXX-XXX-XXLX)	98087	(1)

Item	Description	Part no.	Qty
283	Leak Detector Sensor (PEXX-XXX-XXX-XXEX, PEXX-XXX-XXX-XXLX)	96270-1	(2)
	Leak Detector Sensor ATEX / IECEx (PEXXX-XXX-XXX-XXHX, PEXXX-XXX-XXX-XXMX)	96270-2	(2)
	Leak Detector Sensor NEC/CEC (PEXXX-XXX-XXX-XXMX, PEXXX-XXX-XXX-XXTX)	96270-2	(1)
405	Elbow, Street	97397	(1)
410	ASM, Adapter - Sensor (PE10)	97119	(1)
	ASM, Adapter - Sensor (PE20 and PE30)	97121	(1)
	ASM, Adapter - Sensor (PE15)	97396	(1)
	ASM, Adapter - Sensor (PE10, ATEX/IECEx/NEC/CEC)	97408	(1)
	ASM, Adapter - Sensor (PE15, ATEX/IECEx/NEC/CEC)	97410	(1)
	ASM, Adapter - Sensor (PE20 and PE30, ATEX/IECEx/NEC/CEC)	97411	(1)
7491	Barrier Amplifier, End of Stroke ATEX / IECEx (PEXXX-XXX-XXX-XXGX), (PEXXX-XXX-XXX-XXHX)	97491	(1)
	Barrier Amplifier, End of Stroke NEC / CEC (PEXXX-XXX-XXX-XXRX, PEXX-XXX-XXX-XXTX)	97412	(1)
97414	ZENER Barrier, Leak Detection ATEX (PEXXX-XXX-XXX-XXHX), (PEXXX-XXX-XXX-XXMX), (PEXXX-XXX-XXX-XXTX)	97414	(1)

SOLENOID

GENERAL DESCRIPTION

Without end of stroke feedback, solenoid control can only be used to cycle the pump based on timing. The following curves represent the flow rates of a pump based on timed operation of the solenoid at a common operating point of 70 psig air pressure and 30 psi of back pressure.

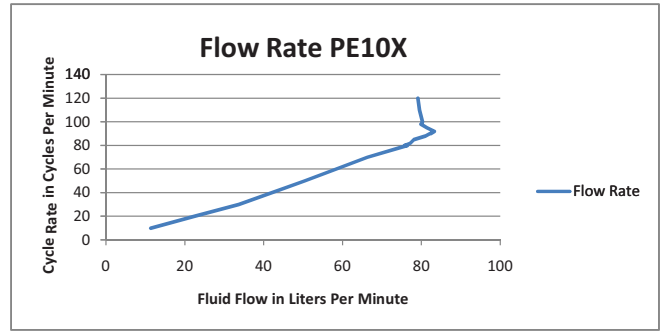
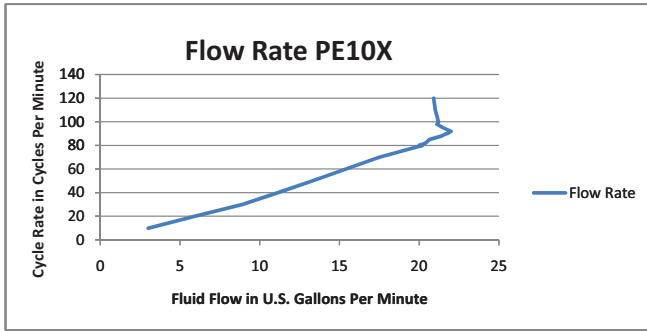

Figure 1

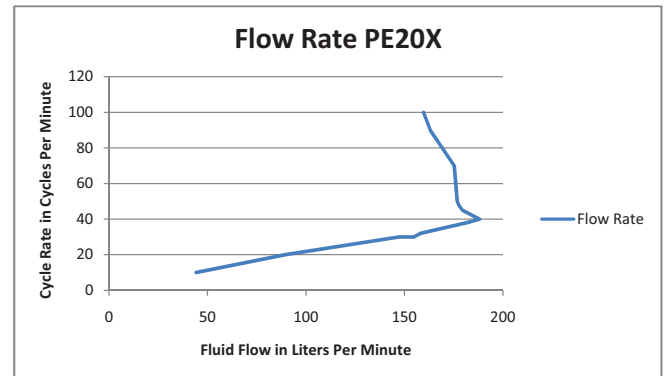
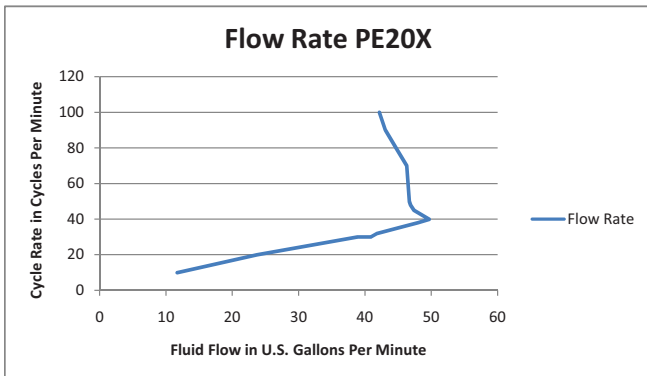

Figure 2

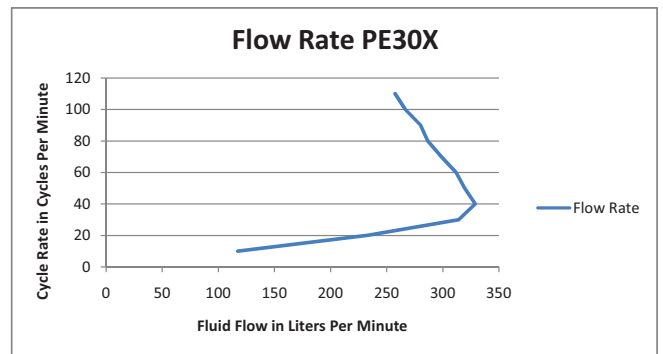
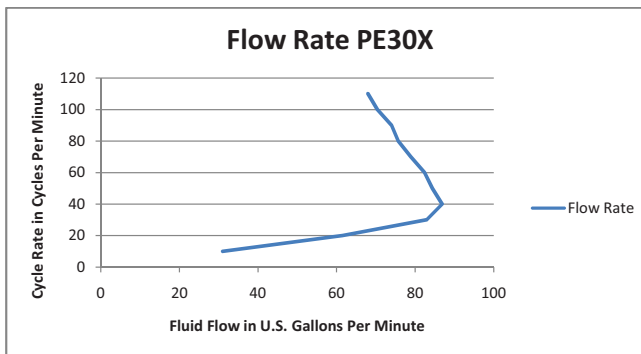
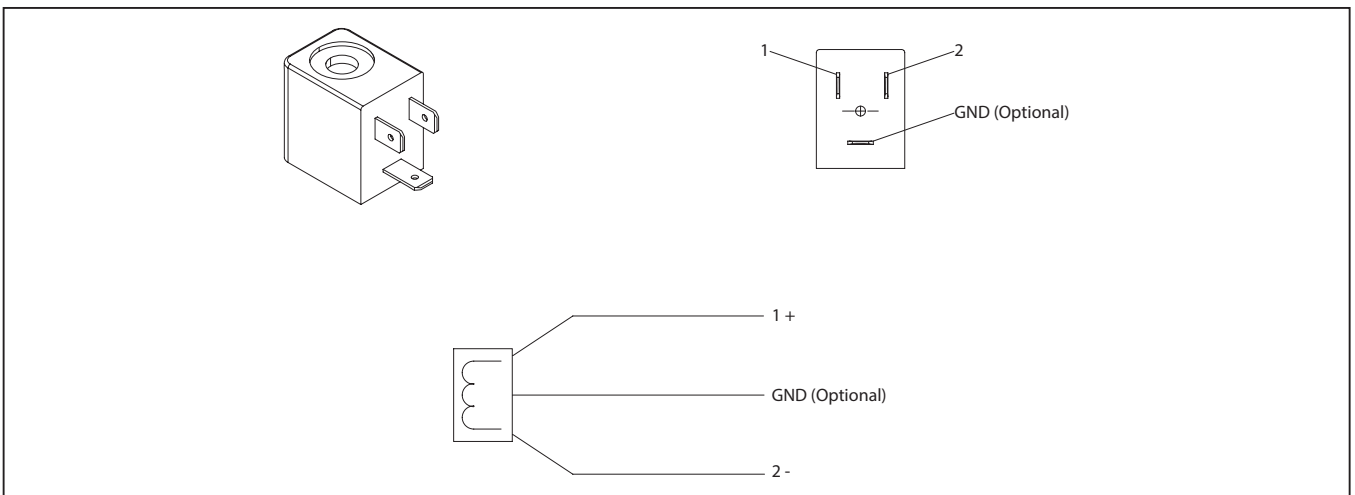

Figure 3

NON - HAZARDOUS DUTY SOLENOID WIRING DIAGRAM



Caution: When running pump while using Electronic Interface / Solenoid Control, it is possible for air inlet pressure to exceed fluid discharge pressure. This pressure differential could cause shortened diaphragm life. Assure that appropriate inlet air pressure is being applied based on application parameters and that the supplied air is shut off and vented when the pump is not in use.

GENERAL DESCRIPTION

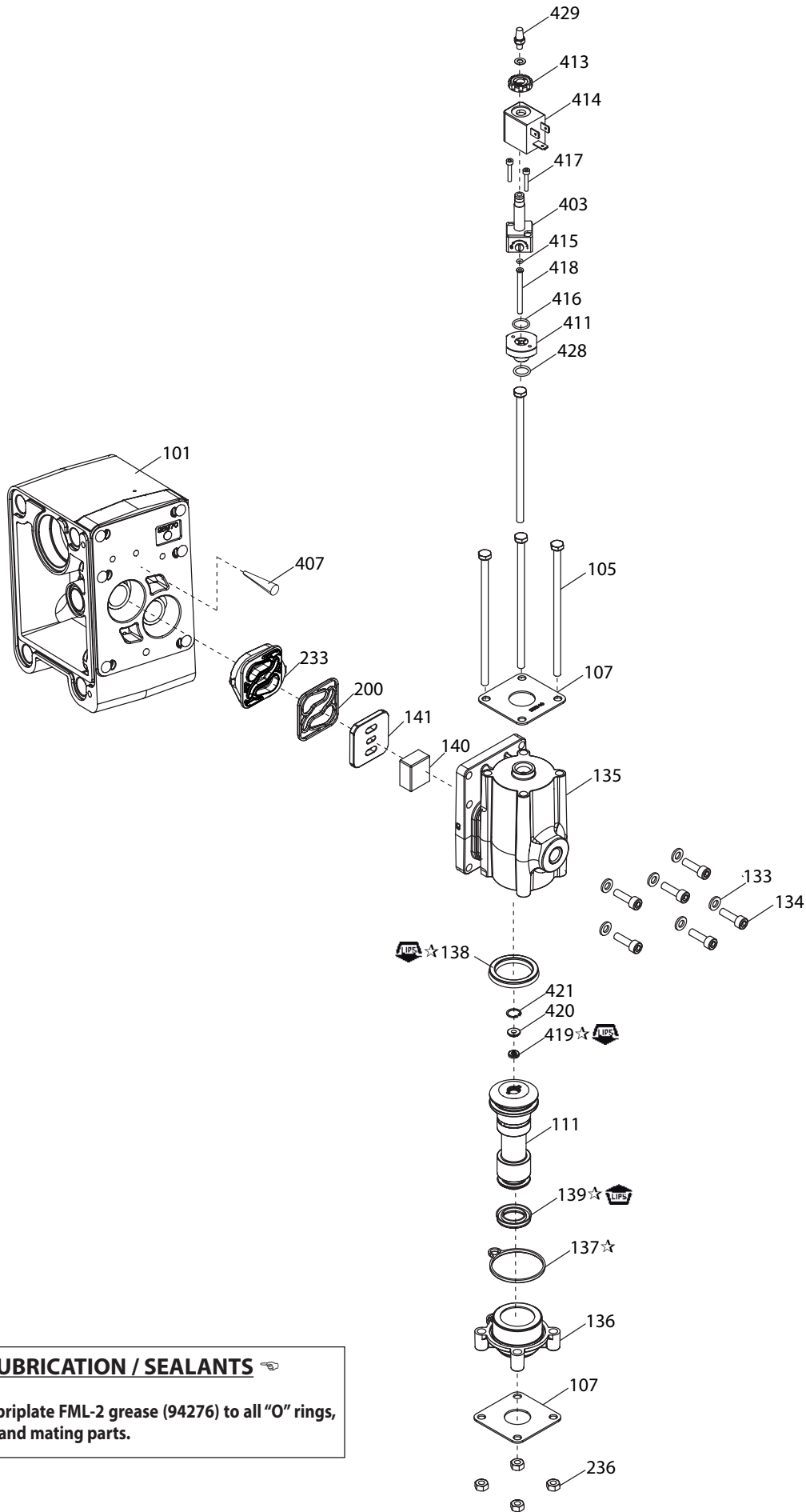

LUBRICATION / SEALANTS

☆ Apply Lubriplate FML-2 grease (94276) to all "O" rings, "U" cups and mating parts.

Figure 4

NON - HAZARDOUS DUTY END OF STROKE

With End of Stroke feedback, the End of stroke sensor detects when the diaphragm rod has reached the end of each stroke. This allows closed loop control of the diaphragm pump, verifying each stroke is complete.

End of Stroke / Cycle Sensor Pinout, M12 Connector

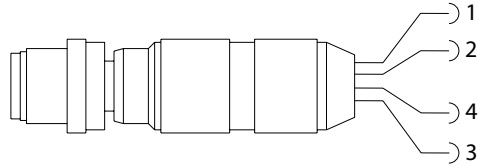
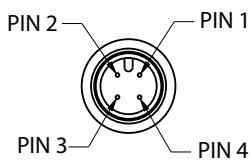

CABLE ASSEMBLY WIRING COLORS:

- PIN 1 - BROWN, POSITIVE VOLTAGE (+10 TO +30 VDC)
- PIN 2 - WHITE, NOT USED
- PIN 3 - BLUE, ZERO VOLTS
- PIN 4 - BLACK, SIGNAL

NOTE: WIRING COLORS ARE BASED ON AUTOMATION DIRECT CD12L AND CD12M 4-POLE CABLE ASSEMBLIES.

End of Stroke / Cycle Sensor Pinout, Wiring Diagram (No Connector)

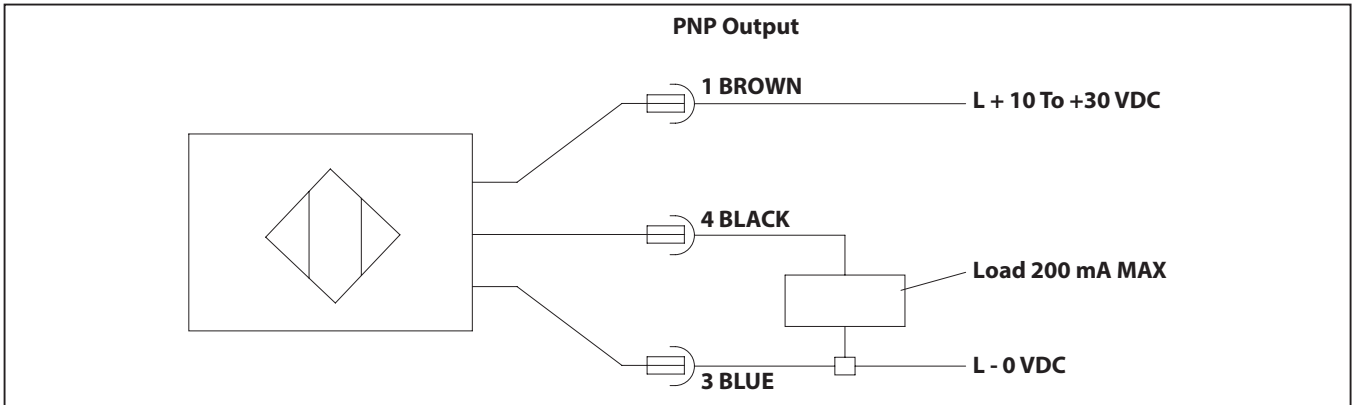

PART LIST

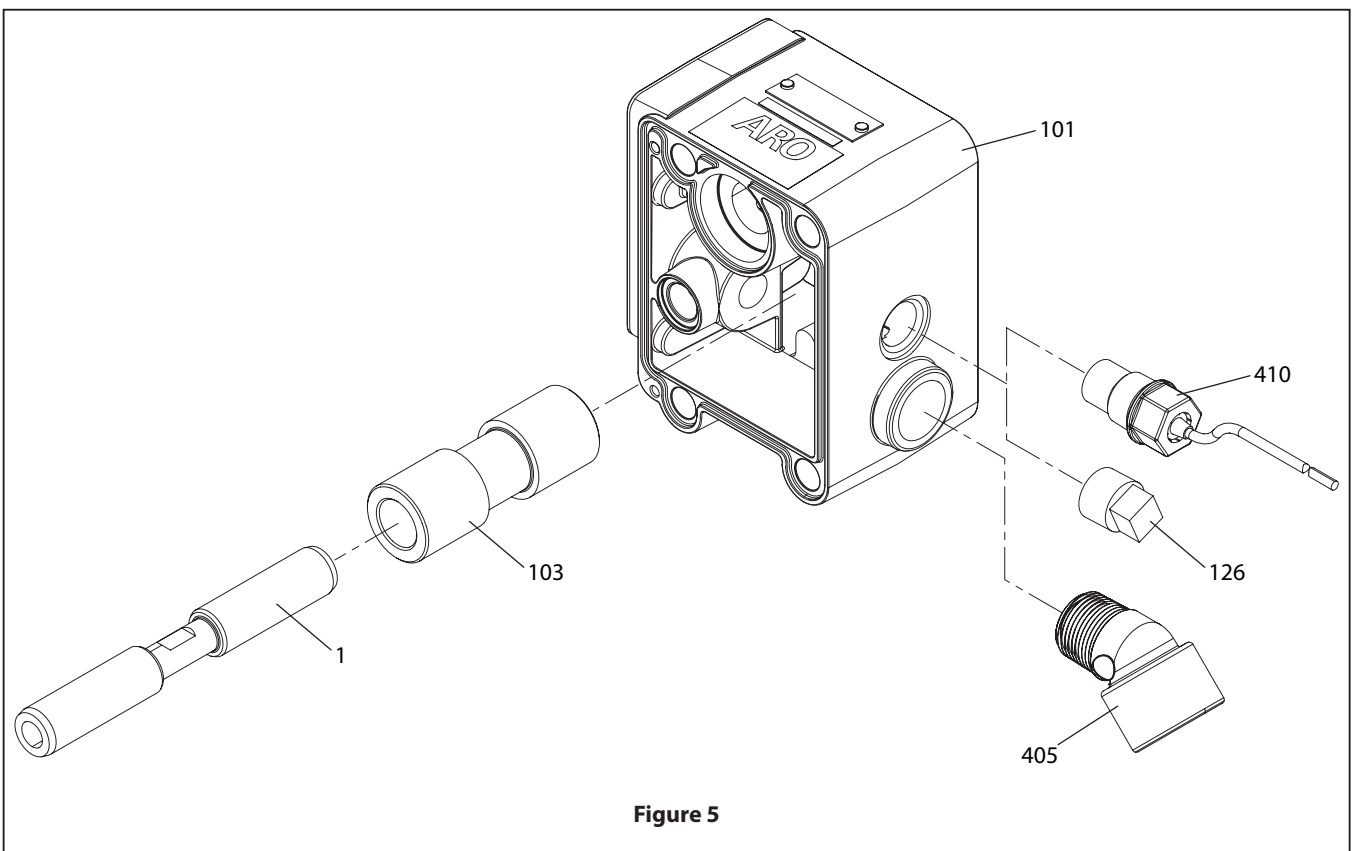

Figure 5

NON - HAZARDOUS DUTY LEAK DETECTION

GENERAL DESCRIPTION

An ARO® diaphragm pump equipped with the ARO Leak Detection Sensor warns of a diaphragm failure by sensing the presence of liquid in the air chamber of the pump. This system uses a liquid sensor in each of the two air chambers which will send an output signal when fluid is detected.

INSTALLATION AND WARNINGS

NOTE: ALL WIRING MUST COMPLY WITH ALL LOCAL AND / OR NATIONAL ELECTRICAL CODES.

- Electrical codes that apply must be strictly adhered to; failure to do so may lead to shock hazard or serious injury.
- Some local electrical codes may require the installation of rigid conduit.

- The Leak Detection Sensor components must be installed by a qualified electrician in compliance with all national, state and local codes and regulations to reduce the risk of electrical shock or other serious injury during installation and operation.
- ARO is not responsible for accidents resulting from improper installation of components or hardware.
- **HAZARDOUS VOLTAGE.** Do not attempt any service without disconnecting all electrical supply sources.

PART LIST / PEXXX-XXX-XXX-XXEX, PEXXX-XXX-XXX-XXLX

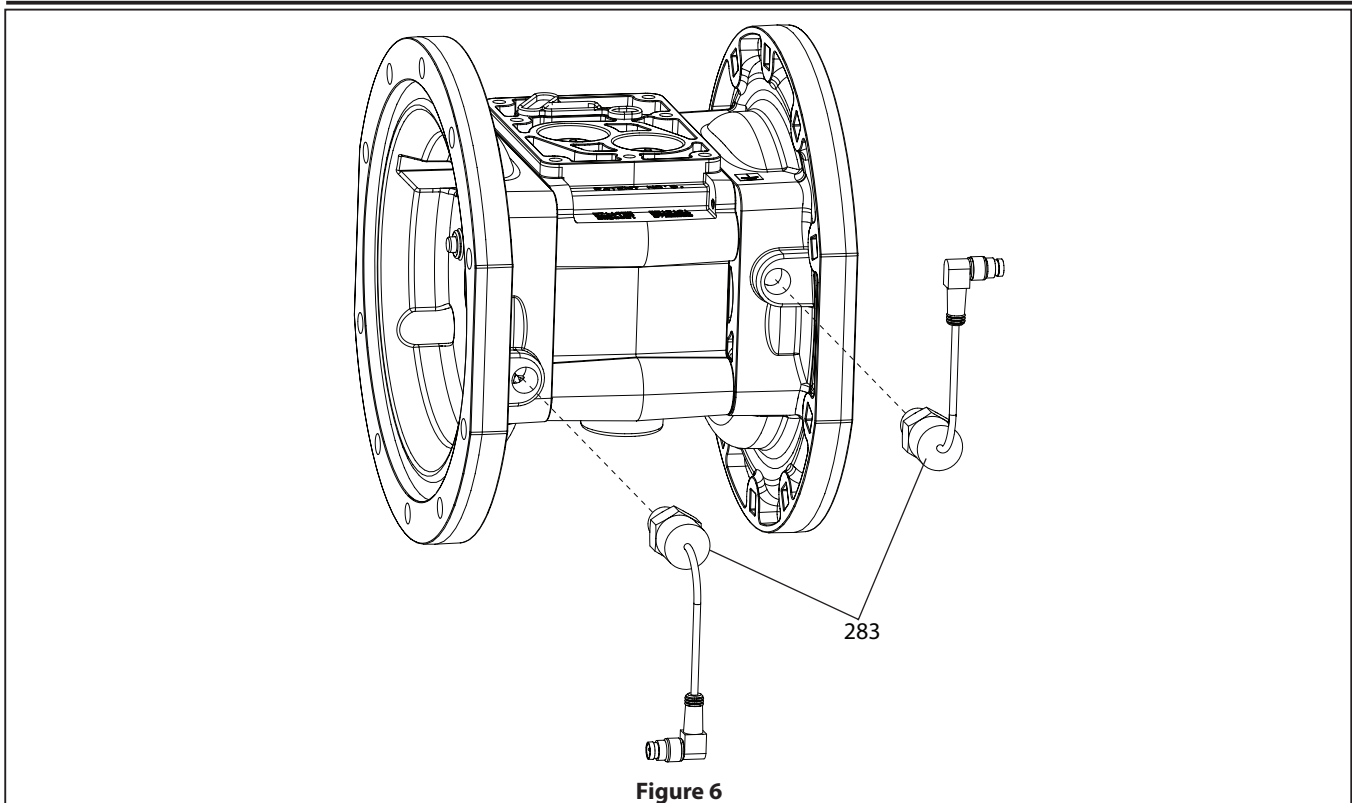

Figure 6

LEAK DETECTION - PINOUT DESCRIPTIONS

96270-1 SENSOR PINOUTS

Pin	Function	Color
1	+24 VDC	Red
3	Ground	Black
4	Signal	White

TURCK (PICOFAST) Connector PSW 3M -2/90

SCHEMATIC

Figure 7

PORTED NO MOTOR OPTIONS

PART LIST- PEXXA-XXX-XXX-XPXX / PEXXS-XXX-XXX-XPXX

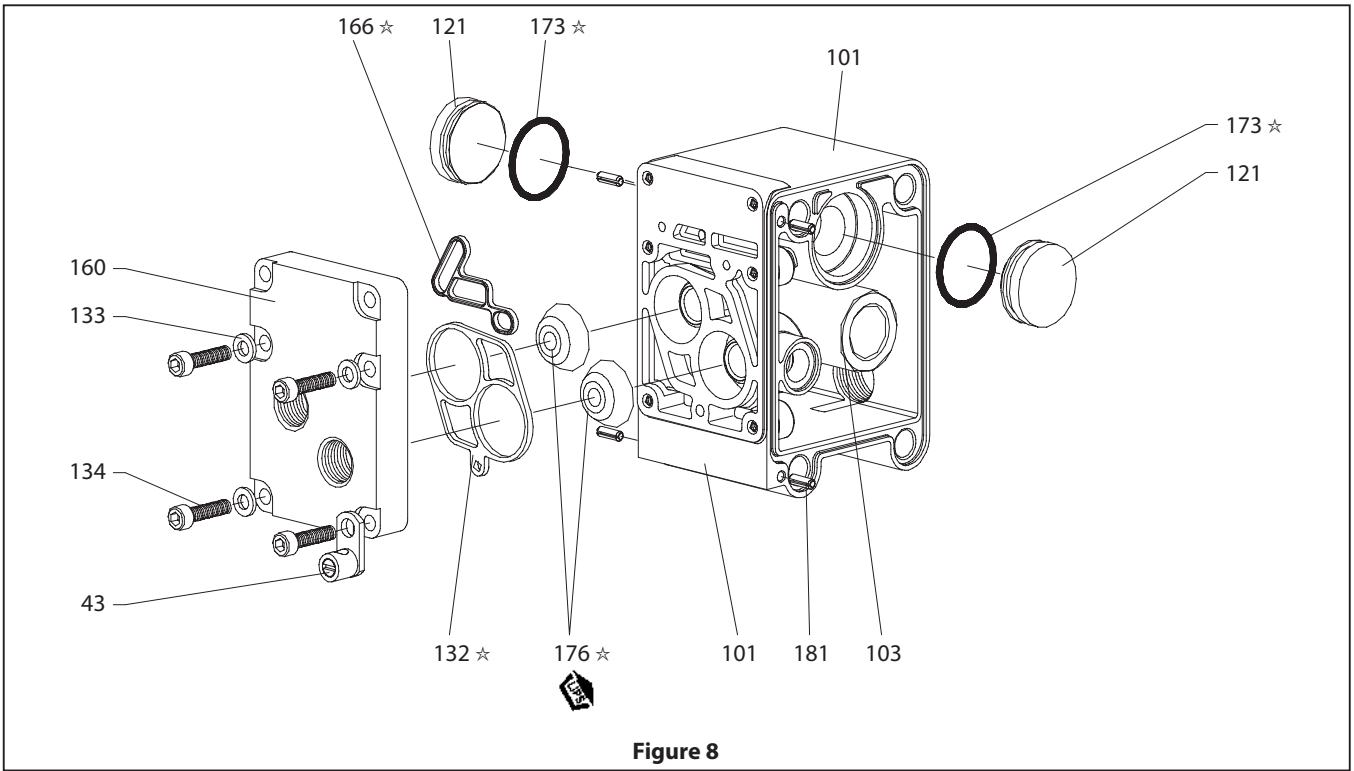

PART LIST - PEXXR-XXX-XXX-XPXX

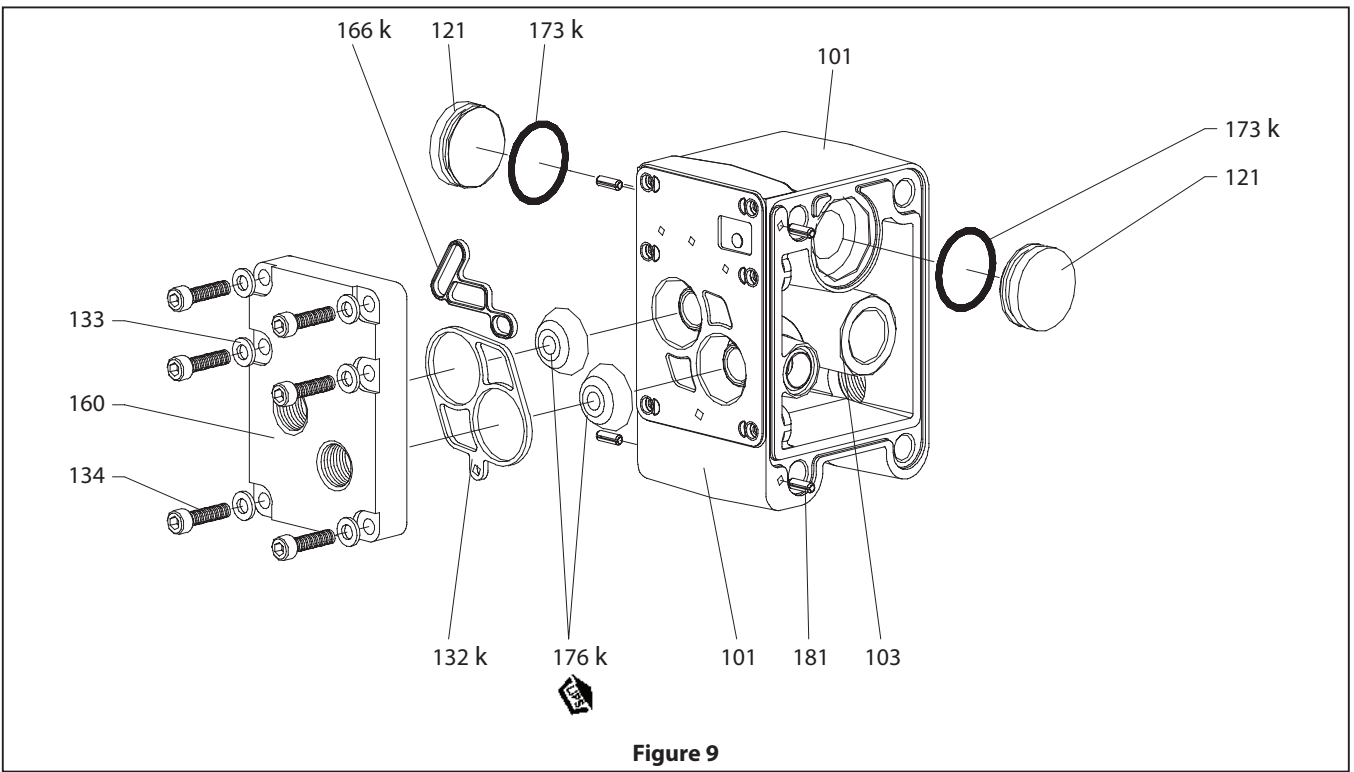

INSTALLATION OF ELECTRONIC INTERFACE COMPONENTS FOR HAZARDOUS DUTY APPLICATIONS

Pumps that will operate in environments defined as “hazardous locations” must only be installed, connected and set-up by qualified personnel with knowledge and understanding of protection classes, regulations and provisions for apparatus in hazardous areas, for the region where the pump will operate, because these regulations and provisions, along with the definition of what constitutes hazardous areas vary by location.

Solenoid PN	Voltage	Device Rating (mA)	Temperature Rating
114772-33	120 VAC	57	-4° F - 140° F (-20° C - 60° C)
114772-38	12 VDC	375	-4° F - 140° F (-20° C - 60° C)
114772-39	24 VDC	191	-4° F - 140° F (-20° C - 60° C)
117345-35 (ATEX)	220 VAC	22	-4° F - 140° F (-20° C - 60° C)
117345-38 (ATEX)	12 VDC	392	-4° F - 140° F (-20° C - 60° C)
117345-39 (ATEX)	24 VDC	192	-4° F - 140° F (-20° C - 60° C)

End of Stroke Proximity Sensor PN	Voltage	Device Rating (mA)	Temperature Rating
97398 (ATEX/IECEX/NEC/CEC)	7.5 - 30 VDC	50	-4° F - 158° F (-20° C - 70° C)
97399 (ATEX/IECEX/NEC/CEC)	7.5 - 30 VDC	50	-4° F - 158° F (-20° C - 70° C)

Barrier Amplifier, End of Stroke PN	Voltage	Device Rating (mA)	Temperature Rating
97491 (ATEX/IECEX)	19.2 - 31.2 VDC	12	-4° F - 140° F (-20° C - 60° C)
97412 (NEC/CEC)	24 VDC	100	-4° F - 140° F (-20° C - 60° C)

Zener Barrier, Leak Detection PN	Voltage	Device Rating (mA)	Temperature Rating
97414 (ATEX/IECEX/NEC/CEC)	24 VDC	100	-4° F - 140° F (-20° C - 60° C)

Leak Detector PN	Voltage	Device Rating (mA)	Temperature Rating
96270-1	24 VDC	40	-0° F - 176° F (-18° C - 80° C)
96270-2 (ATEX/IECEX)	24 VDC	40	-0° F - 176° F (-18° C - 80° C)

Maximum process fluid and ambient temperatures should not exceed 50° C.

HAZARDOUS DUTY EI PUMP WIRING DIAGRAMS

LEAK DETECTION SENSORS

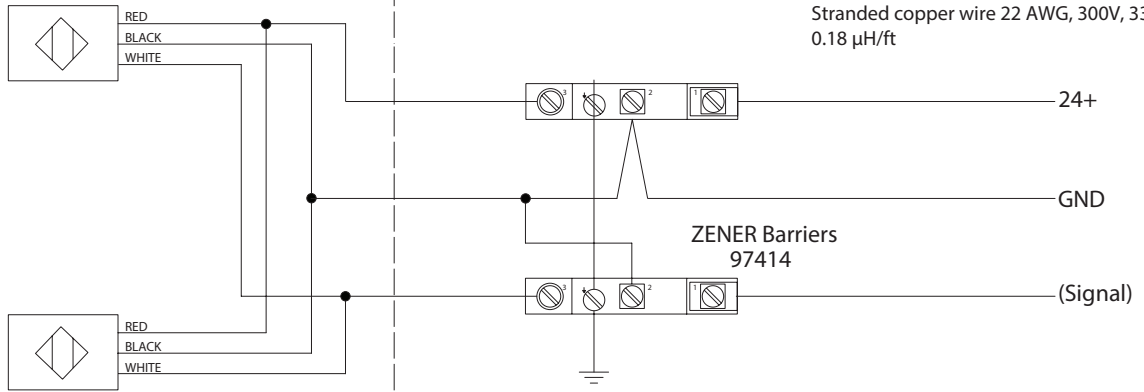

END OF STROKE SENSOR

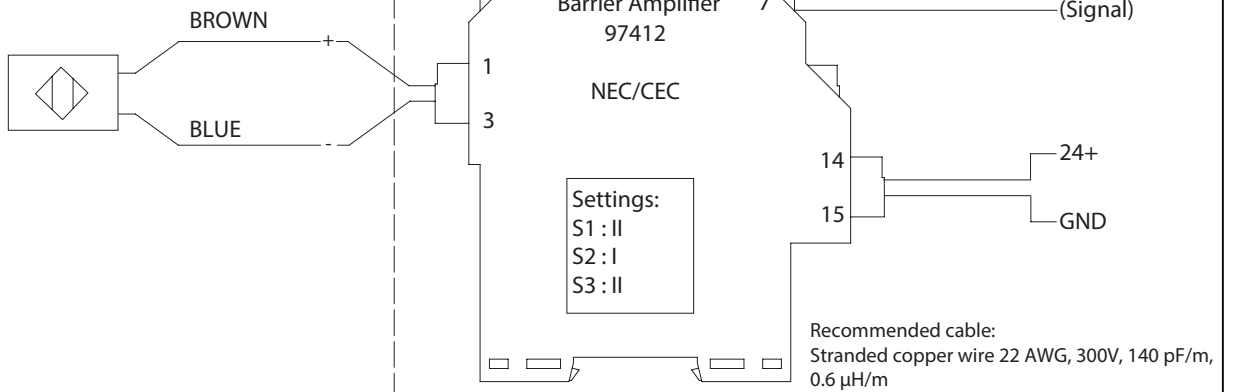

END OF STROKE SENSOR

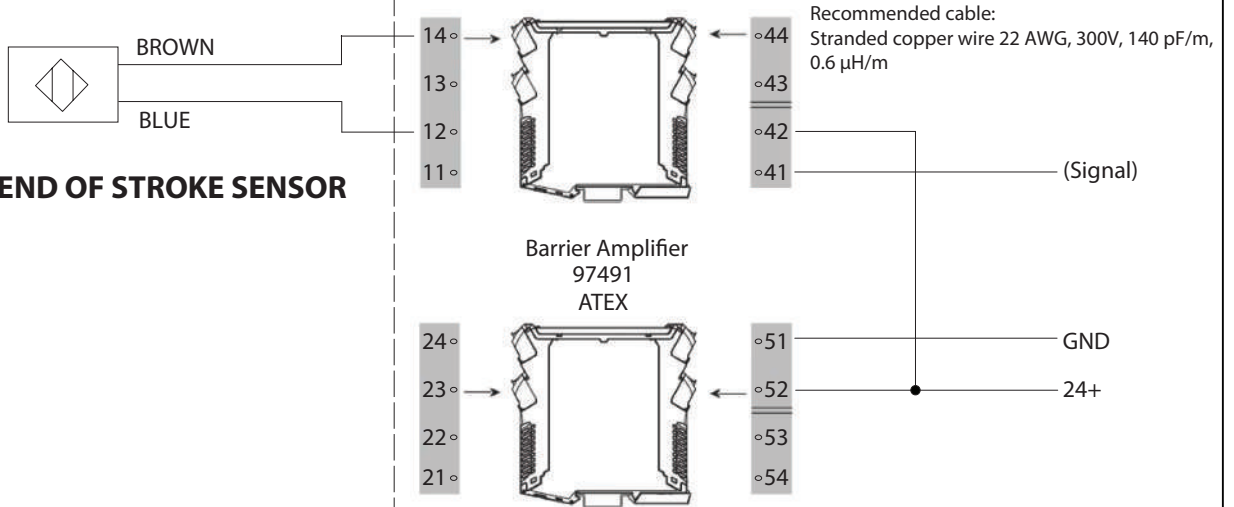

SOLENOID COIL

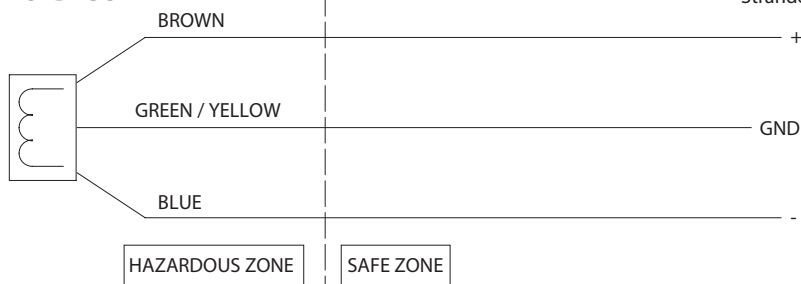

Figure 10

NOTE: Installer is responsible for extending cables and bringing them outside hazardous area using approved methods and components.

Notes
