

**BINKS®**

# Maple 15/3 Pump

Model 104009

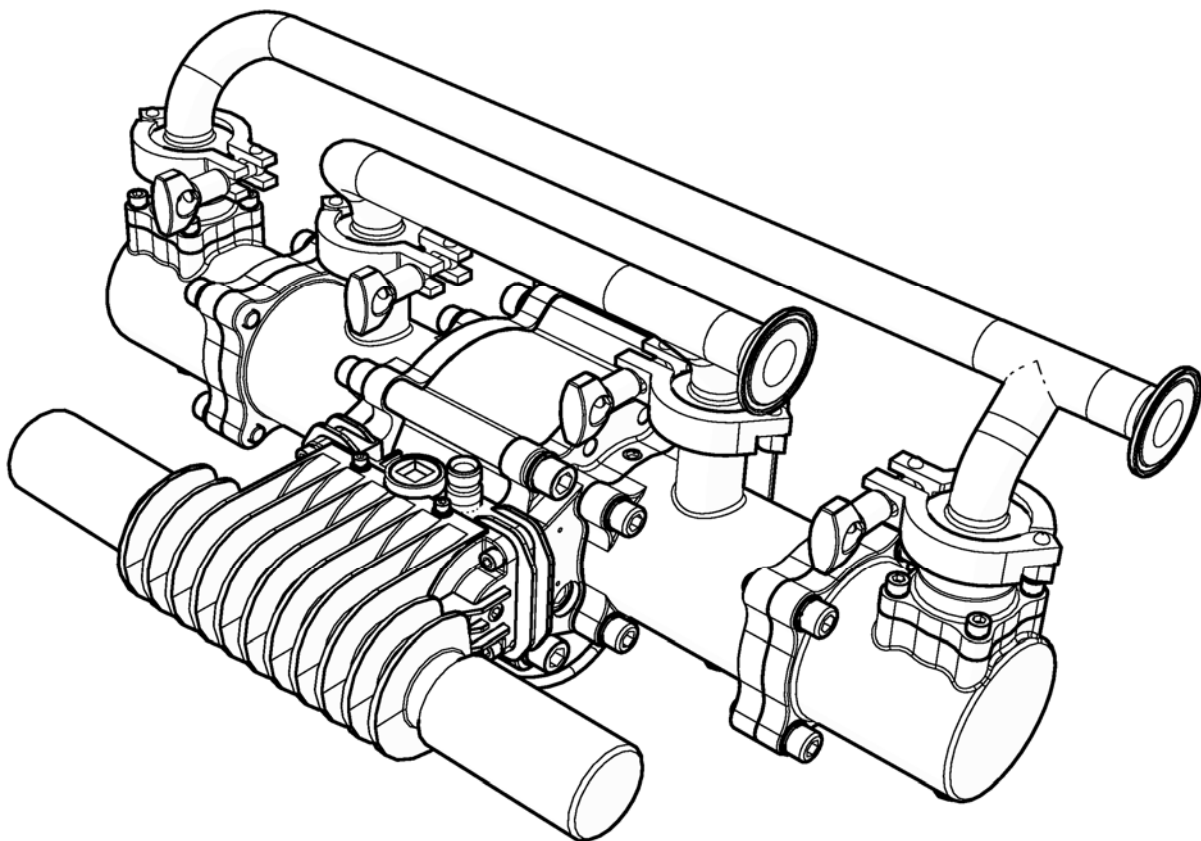

## **IMPORTANT! DO NOT DESTROY**

It is the Customer's responsibility to have all operators and service personnel read and understand this manual.

Contact your local Carlisle Fluid Technologies representative for additional copies of this manual.

**READ ALL INSTRUCTIONS BEFORE OPERATING THIS PRODUCT**

<b>Product Description / Object of Declaration:</b>	<b>Pumps - Maple, DVP, 104009, 104010/LS, 104016, 104027, 104032, 104040/1/2, 104077, 104020, 104023, 104025, 104028/9, 106933, 104205, 104149-52, 104207-15, 104147.</b>	<b>EN</b>
<b>This Product is designed for use with:</b>	Solvent and Water based materials	
<b>Suitable for use in hazardous area:</b>	Zone 1	
<b>Protection Level:</b>	II 2 G X IIB T4	
<b>Notified body details and role:</b>	Element Materials Technology (0891) Lodging of Technical file	
<b>This Declaration of conformity / incorporation is issued under the sole responsibility of the manufacturer:</b>	Carlisle Fluid Technologies UK Ltd, Ringwood Road, Bournemouth, BH11 9LH. UK	

## EU Declaration of Conformity



**This Declaration of conformity / incorporation is issued under the sole responsibility of the manufacturer:**

Machinery Directive 2006/42/EC

ATEX Directive 2014/34/EU

by complying with the following statutory documents and harmonized standards:

EN ISO 12100:2010 Safety of Machinery - General Principles for Design

EN 12621:+A1:2010 Machinery for the supply and circulation of coating materials under pressure - Safety requirements

EN 1127-1:2011 Explosive atmospheres - Explosion prevention - Basic concepts

EN 13463-1:2009 Non electrical equipment for use in potentially explosive atmospheres - Basic methods and requirements

EN 13463-5:2011 Non electrical equipment for use in potentially explosive atmospheres - Protection by constructional safety "c"

Providing all conditions of safe use / installation stated within the product manuals have been complied with and also installed in accordance with any applicable local codes of practice.

Signed for and on behalf of Carlisle Fluid  
Technologies UK Ltd:

D Smith



Director of Sales (EMEA)

27/6/18

Bournemouth, BH11 9LH, UK

In this part sheet, the words WARNING, CAUTION and NOTE are used to emphasize important safety information as follows:

**EN**

 <b>WARNING</b>	 <b>CAUTION</b>	<b>NOTE</b>
Hazards or unsafe practices which could result in severe personal injury, death or substantial property damage.	Hazards or unsafe practices which could result in minor personal injury, product or property damage	Important installation, operation or maintenance information.

 **WARNING**

Read the following warnings before using this equipment.



**READ THE MANUAL.** Before operating finishing equipment, read and understand all safety, operation and maintenance information provided in the operation manual.



**AUTOMATIC EQUIPMENT.** Automatic equipment may start suddenly without warning.



**WEAR SAFETY GLASSES.** Failure to wear safety glasses with side shields could result in serious eye injury or blindness.

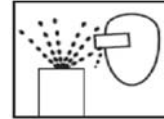

**PROJECTILE HAZARD.** You may be injured by venting liquids or gases that are released under pressure, or flying debris.



**DE-ENERGIZE, DE-PRESSURISE, DISCONNECT AND LOCK OUT ALL POWER SOURCES DURING MAINTENANCE.** Failure to de-energize, disconnect and lock out all power supplies before performing equipment maintenance could cause serious injury or death.



**KNOW WHERE AND HOW TO SHUT OFF THE EQUIPMENT IN CASE OF AN EMERGENCY.**



**NOISE LEVELS.** The A-weighted sound level of pumping and spray equipment may exceed 85 dB(A) depending on equipment settings. Actual noise levels are available on request. It is recommended that ear protection is worn at all times while equipment is in use.



**PRESSURE RELIEF PROCEDURE.** Always follow the pressure relief procedure in the equipment instruction manual.



**INSPECT THE EQUIPMENT DAILY.** Inspect the equipment for worn or broken parts on a daily basis. Do not operate the equipment if you are uncertain about its condition.



**OPERATOR TRAINING.** All personnel must be trained before operating finishing equipment.



**EQUIPMENT MISUSE HAZARD.** Equipment misuse can cause the equipment to rupture, malfunction or start unexpectedly and result in serious injury.



**PACEMAKER WARNING.** You are in the presence of magnetic fields which may interfere with the operation of certain pacemakers.



**HIGH PRESSURE CONSIDERATION.** High pressure can cause serious injury. Relieve all pressure before servicing. Spray from the gun, hose leaks or ruptured components can inject fluid into your body and cause extremely serious injury.



**KEEP EQUIPMENT GUARDS IN PLACE.** Do not operate the equipment if the safety devices have been removed.



**STATIC CHARGE.** Fluid may develop a static charge that must be dissipated through proper grounding of the equipment, objects to be sprayed and all other electrically conductive objects in the dispensing area. Improper grounding or sparks can cause a hazardous condition and result in fire, explosion or electric shock and other serious injury.



**NEVER MODIFY THE EQUIPMENT.** Do not modify the equipment unless the manufacturer provides written approval.



**PROP 65 WARNING.** WARNING: This product contains chemicals known to the state of California to cause cancer and birth defects or other reproductive harm.



**PINCH POINT HAZARD.** Moving parts can crush and cut. Pinch points are any areas where there are moving parts.

**IT IS THE RESPONSIBILITY OF THE EMPLOYER TO PROVIDE THIS INFORMATION TO THE OPERATOR OF THE EQUIPMENT.**

## Specification

Ratio:	3:1
Maximum air inlet pressure:	7 bar [101.5 psi]
Maximum fluid pressure:	21 bar [304.5 psi]
Nominal flow volume / cycle:	0.375 l/m [0.10 US gal/m]
Output @ 60 cycles / min:	22.5 l/m [6 US gal/m]
Maximum recommended continuous cycle rate:Cycles/min	20
Maximum recommended intermittent cycle rate:Cycles/min	40
Fluid inlet connection:	1" Sanitary
Fluid outlet connection:	1" Sanitary
Compressed Air Inlet	3/8" BSPP / NPSM
Air volume / cycle @ 3.1 bar/45psi:	4.8 l/m [0.17 SCFM] @ 3.1 bar [45 psi]
Air volume / cycle @ 6.2 bar/90psi:	9.3 l/m [0.33 SCFM] @ 90 psi [6.2 bar]
Air consumption @ 15 cycles/min and 6 bar [87 psi] air inlet pressure:	142 l/m [5 CFM]
Air consumption @ 30 cycles/min and 6 bar [87 psi] air inlet pressure:	283 l/m [10CFM]
Max. Pump Fluid Inlet Pressure	2 bar [30 psi]
Air Quality ISO 8573.1 Class 3.3.2 # See Note	Dirt: 5 microns Water: -20°C @ 7bar [940ppm] Oil: 0.1mg/m <sup>3</sup>
Weight:	21 kg / 46 lbs

# Note: Class 3.4.2 Air Quality (Refrigerant dried - water +3°C@7bar) may be used, however, above 15 cycles/min optional heavy duty mufflers 192821 or piped exhaust system should be used, if used continuously.

**Dimensions and Mounting Details**

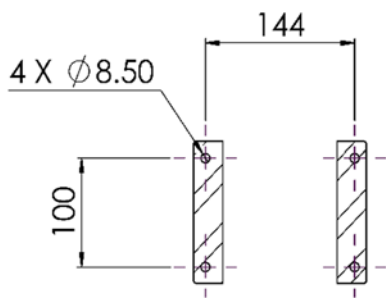
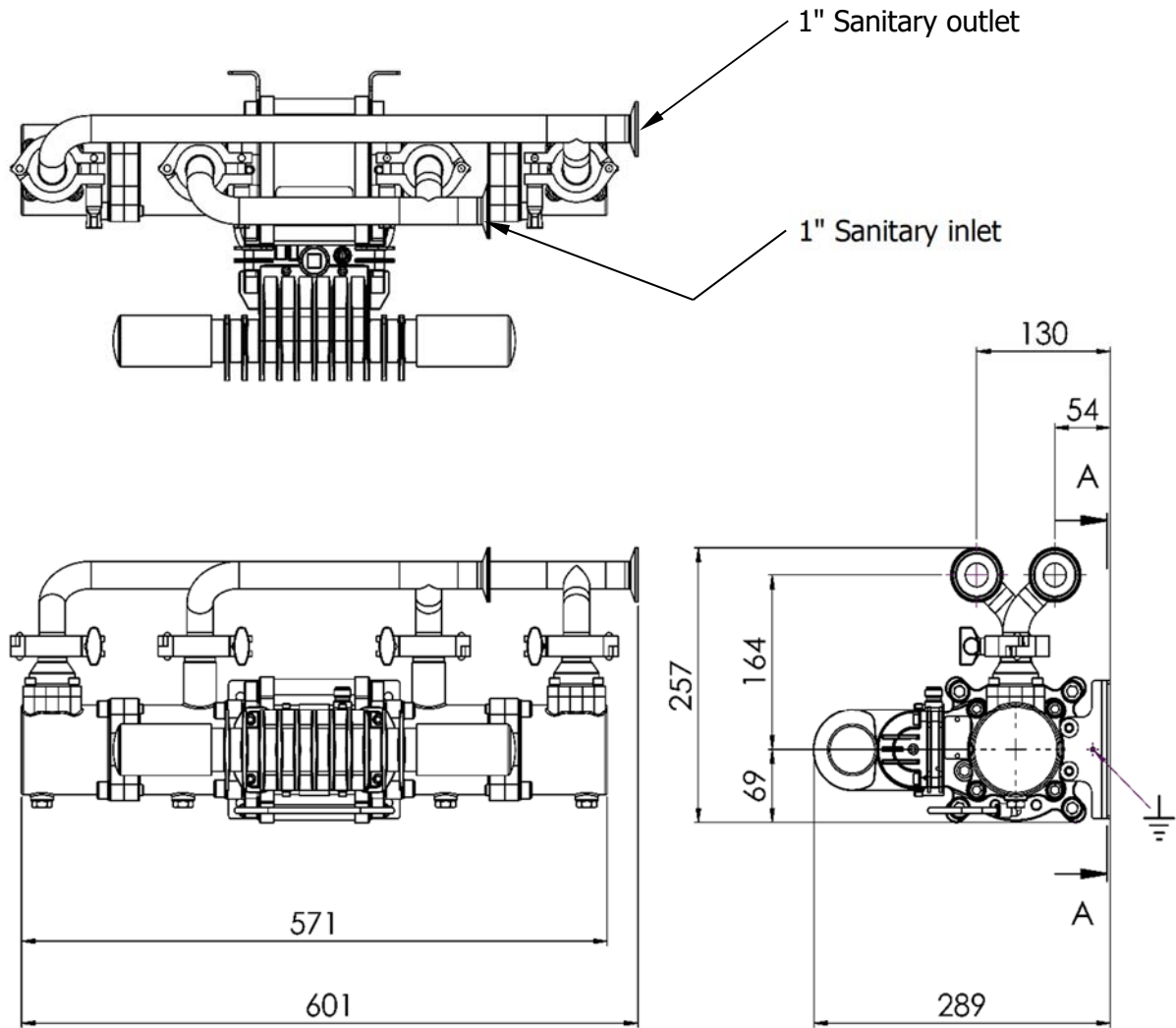

**MOUNTING LOCATIONS  
SECTION A-A**

## Installation

*This product should be flushed with a suitable compatible solvent prior to use.*

Mount the pump securely and position the pump at a convenient height (below the lid height of the paint container), to allow for maintenance, visual observation, and periodic inspection.

The wall mount bracket is included with all pumps.

The Pump Mounting bracket must be connected to a suitable earth ground to ensure that there is no possibility of static build up.

Attach suitable flexible hoses to the inlet and outlet connections.

Connect a suitable 3/8" NB air hose and 1/2" Pressure Filter Regulator to the air motor.

(Filter rated at minimum 1000 l/min)

No additional air lubrication is required as piston ring lubricant is applied during assembly or repair.

If an air lubricator is used then, this must be maintained.

## Installation

Set the pump speed to a slow cycle rate and prime the pump to remove any air before increasing pressure.

Inspect for any air or fluid leaks.

Set the pump cycle rate to achieve the required paint volume and then adjust the system back pressure regulator and pump air pressure to achieve the desired system fluid pressure.

A Back Pressure Regulator should be mounted in the paint system return line.

The return line 'back pressure' regulator responds to the changes in system fluid flow demand, (due to variable paint usage) by dynamically adjusting the paint flow rate returning to the system paint tank, thus maintaining the set pressure.

If an air blow out system is used, never exceed 2 bar [29 psi] on the inlet of the pump.

Exhaust kits are available for these pumps if the air exhaust is required to be piped away from the pump rather than exhausting locally through the mufflers.

## Parts list - Pump Assembly

ITEM	PART NO.	DESCRIPTION	QTY	REMARKS
1	163952	M6 x 21 HEX HEAD CAP SCREW	8	
2	165087	M6 SPRING WASHER	8	
3	165123	M10 SPRING WASHER	16	
4	165947	M10 x 35 SOCKET HEAD CAP SCREW	16	
5	192009	1" & 1 1/2" SANITARY CLAMP	4	
6	192206	1" PTFE SANITARY GASKET	4	① ②
7	192382	Ø25.4 BALL	2	②
8	192505	Ø12.42 x 1.78 O-RING	4	①
9	192551	1/4" HEXAGON PLUG	4	②
10	192712	Ø37.82 x 1.78 O-RING	4	① ②
11	192825	INLET CYLINDER	2	
12	192826	OUTLET CYLINDER	2	
13	192827	OUTLET CHECK	2	
14	162844	PISTON SEAL	2	① ②
15	192833	SEAT	2	②
16	192834	INLET MANIFOLD	1	
17	192835	OUTLET MANIFOLD	1	
18	193703	AIR MOTOR ASSEMBLY	1	
19	194242	Ø70 PISTON ASSEMBLY	2	



# Pump Assembly

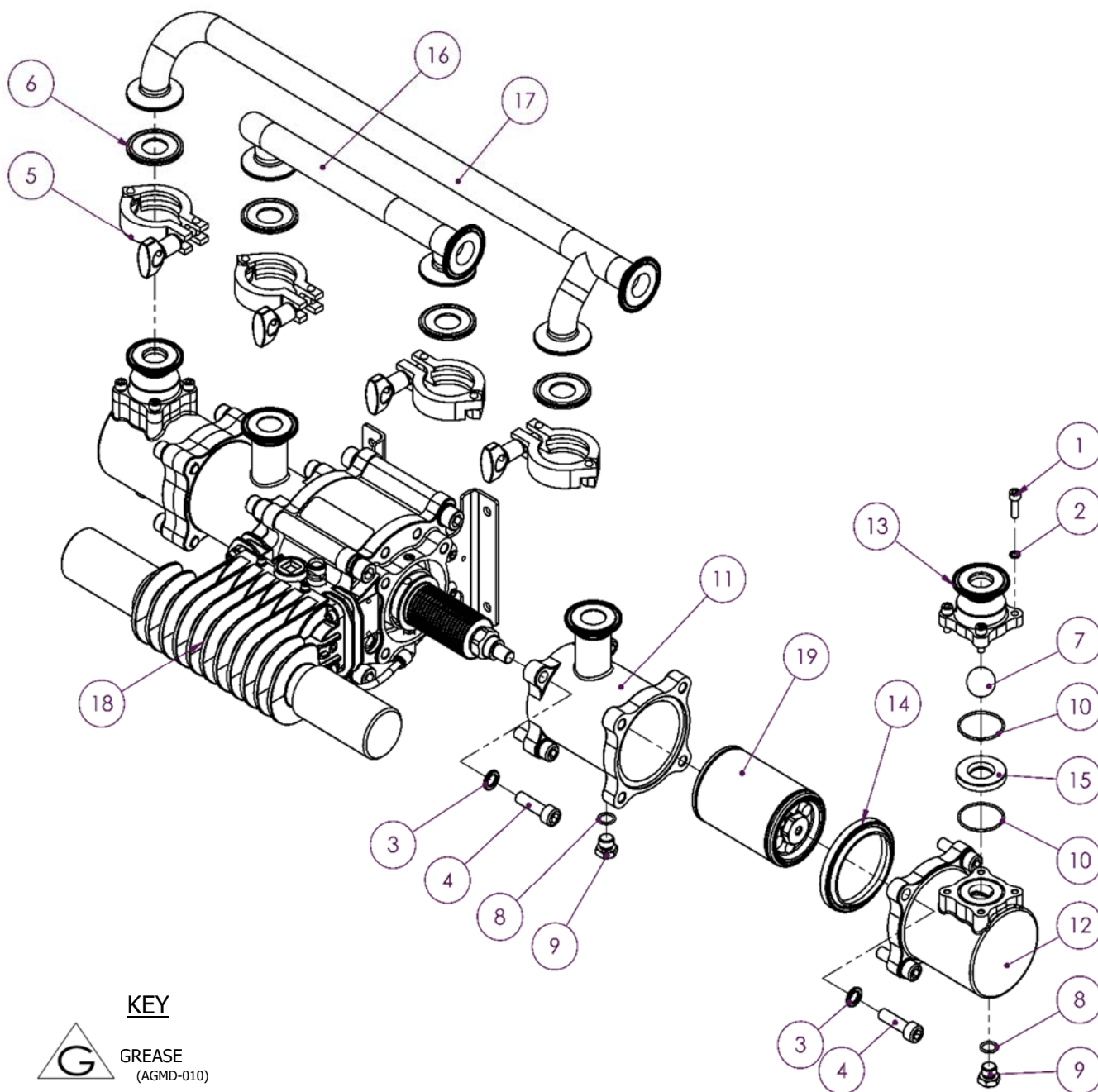

**KEY**

**G** GREASE  
(AGMD-010)

**###** LOCTITE





**##Nm** TORQUE

**#** MAINTENANCE ORDER  
(Reverse for assembly)

**GI** GREASE INTERNAL  
(AGMD-010)

## Parts list - Air Motor Assembly

ITEM	PART NO.	DESCRIPTION	QTY	REMARKS
1	0115-010037	POPPET ASSEMBLY	2	④
2	0115-010102	AIR VALVE ASSEMBLY	1	
3	161993	Ø20.35 x 1.78 VITON O-RING	2	⑤
4	161994	Ø4.47 x 1.78 O-RING	4	⑤
5	161995	Ø19.5 x 3.00 O-RING	2	⑤
6	161998	Ø125 x 2.00 O-RING	2	⑤
7	162703	SHAFT SEAL	2	⑤
8	162704	SHAFT BEARING	2	⑤
9	162707	AIR MOTOR PISTON SEAL	1	⑤
10	163920	M6 x 30 SS SET SCREW	4	
11	165044	M12 SS SPRING WASHER	8	
12	165123	M10 SS SPRING WASHER	4	
13	165528	M4 x 16 SS SOCKET HEAD CAP SCREW	4	
14	165960	M12 x 40 SS SOCKET HEAD CAP SCREW	8	
15	165970	M4 SS PLAIN WASHER	4	
16	165971	Ø4 SS SPRING WASHER	4	
17	165973	M12 x 46 GRUB SCREW	1	
18	177038	M10 x 13 BUTTON HEAD CAP SCREW	4	
19	192374	RETAINING NUT	2	
20	192579	KNIFED BELLOWS	2	# ②
21	192759	PISTON SHAFT	2	
22	192763	BELLOWS SPACER	2	
23	192764	PUMP BRACKET	2	
24	192799	VENT PLUG	2	
25	192812	EXHAUST ADAPTER	1	
26	192814	BELLOWS LEAK DETECTION HOSE	1	⑤
27	192815	PUSH IN ELBOW	2	1/8R - 6mm
28	192830	END PLATE MACHINING	2	
29	192831	AIR CYLINDER	1	
30	192832	AIR MOTOR PISTON	1	

- KEY**
-  GREASE (AGMD-010)
  -  LOCTITE
  -  TORQUE
  -  MAINTENANCE ORDER (Reverse for assembly)
  -  GREASE INTERNAL (AGMD-010)

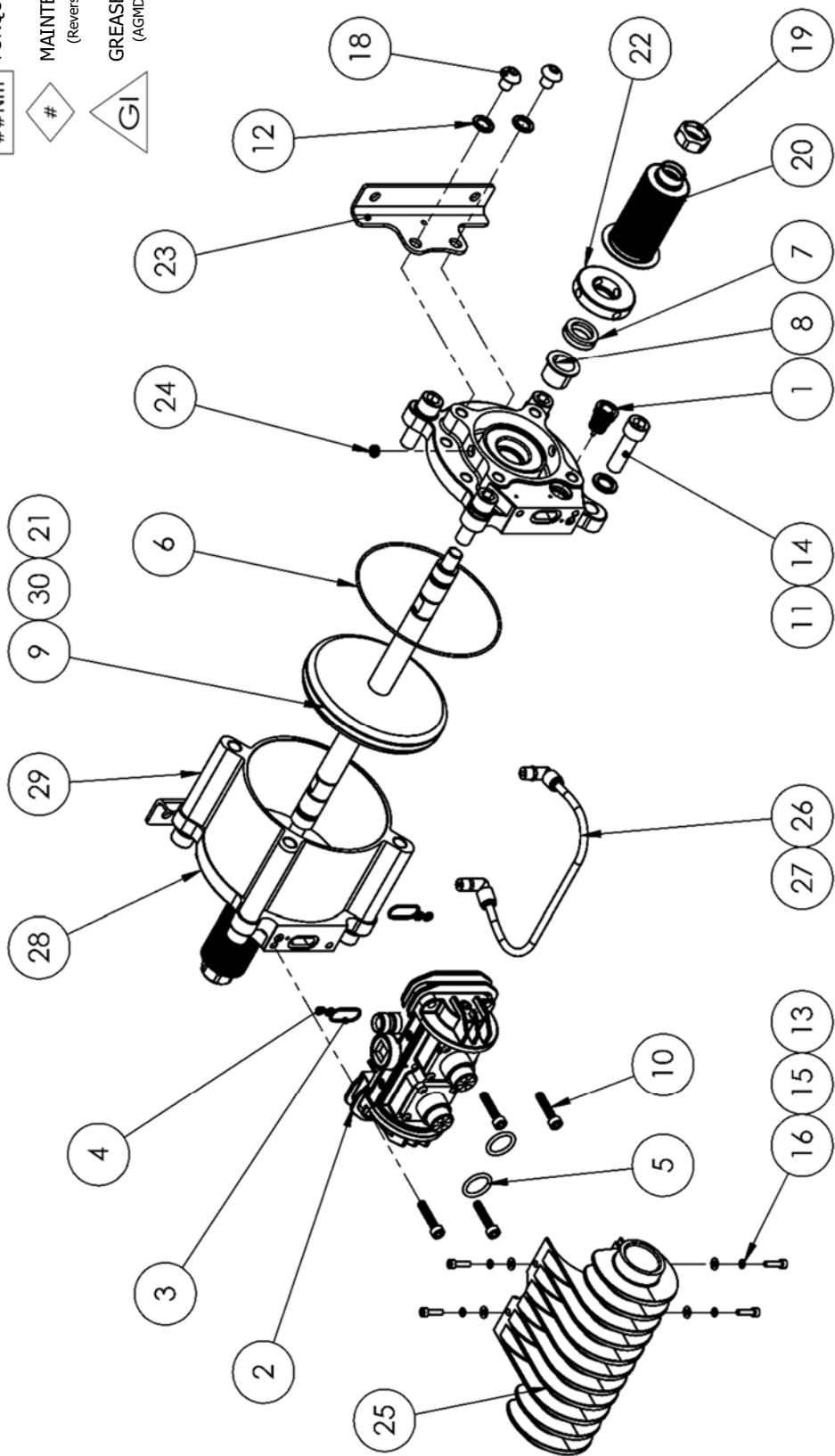

ITEM 7  
DETAIL



## Air Motor Piston Assembly

ITEM	PART NO.	DESCRIPTION	QTY	REMARKS
1	162707	AIR MOTOR PISTON SEAL	1	⊕
2	165973	M12 x 41 GRUB SCREW	1	
3	192759	PISTON SHAFT	2	
4	192832	PISTON	1	

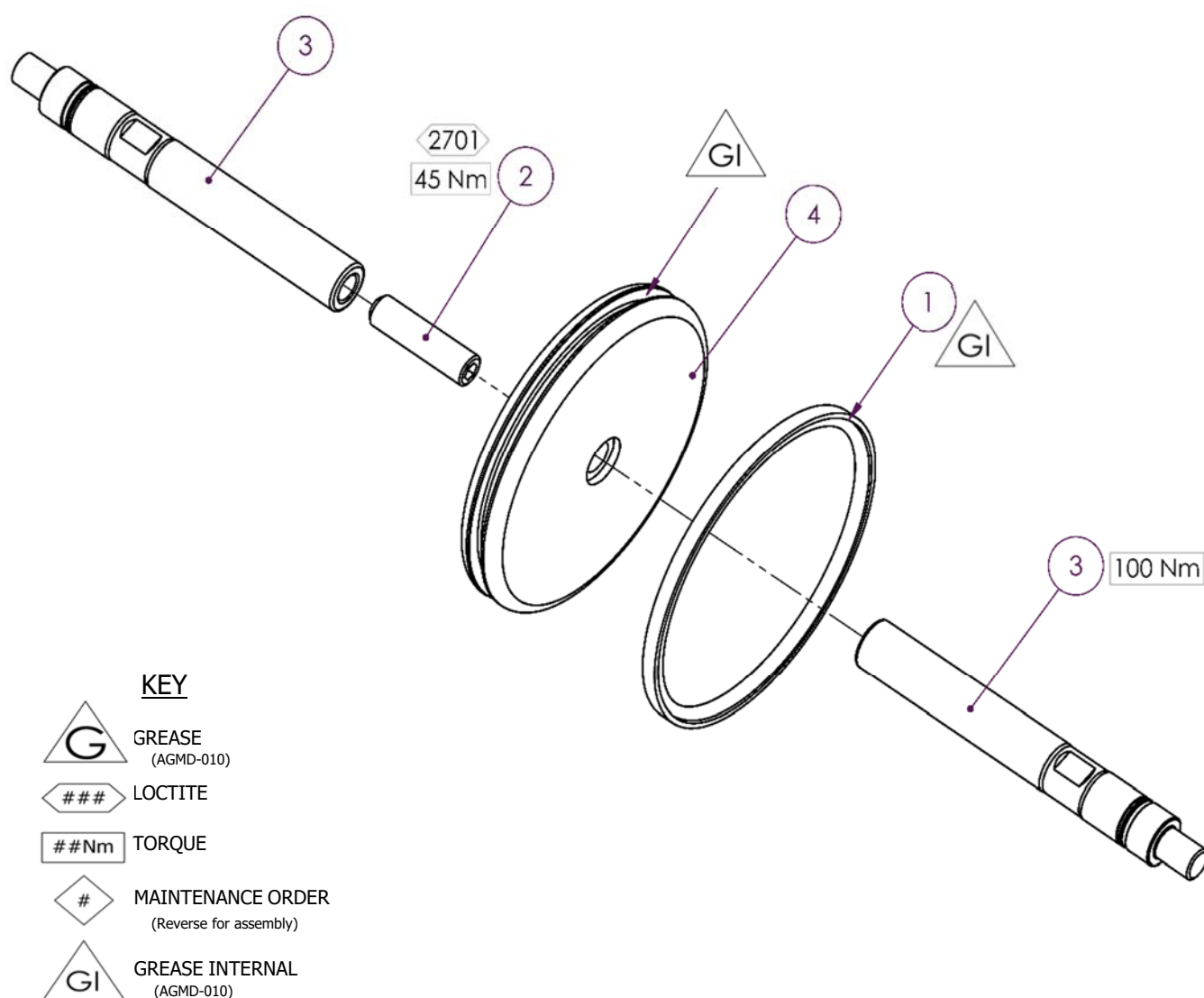

## Air Valve Assembly

ITEM	PART NO.	DESCRIPTION	QTY	REMARKS
1	0115-010015	SPOOL AND SLEEVE ASSEMBLY	1	④ #
	162789	SPOOL AND SLEEVE O-RING	6	<i>Not Shown</i>
2	0115-010016	BUMPER	2	④
3	0115-010017	MAGNET	2	④
4	0115-010018	VALVE BLOCK END CAP	2	
5	0115-010020	DIAPHRAGM	2	⑤
6	0115-010021	1.5 x 36 O-RING	2	⑤
7	0115-010049	2 x 20 O-RING	2	④
8	0115-010073	M4 x 12 SS BUTTON HEAD CAP SCREW	8	
9	0115-010097	VALVE BLOCK	1	
10	0115-010103	1/4 BSPT PIPE PLUG	1	
11	0115-010107	1/8 BSPT PIPE PLUG	1	
12	180584	3/8" UNIVERSAL FITTING	1	
13	192813	QUICK EXHAUST VALVE CAGE	2	

**KEY**

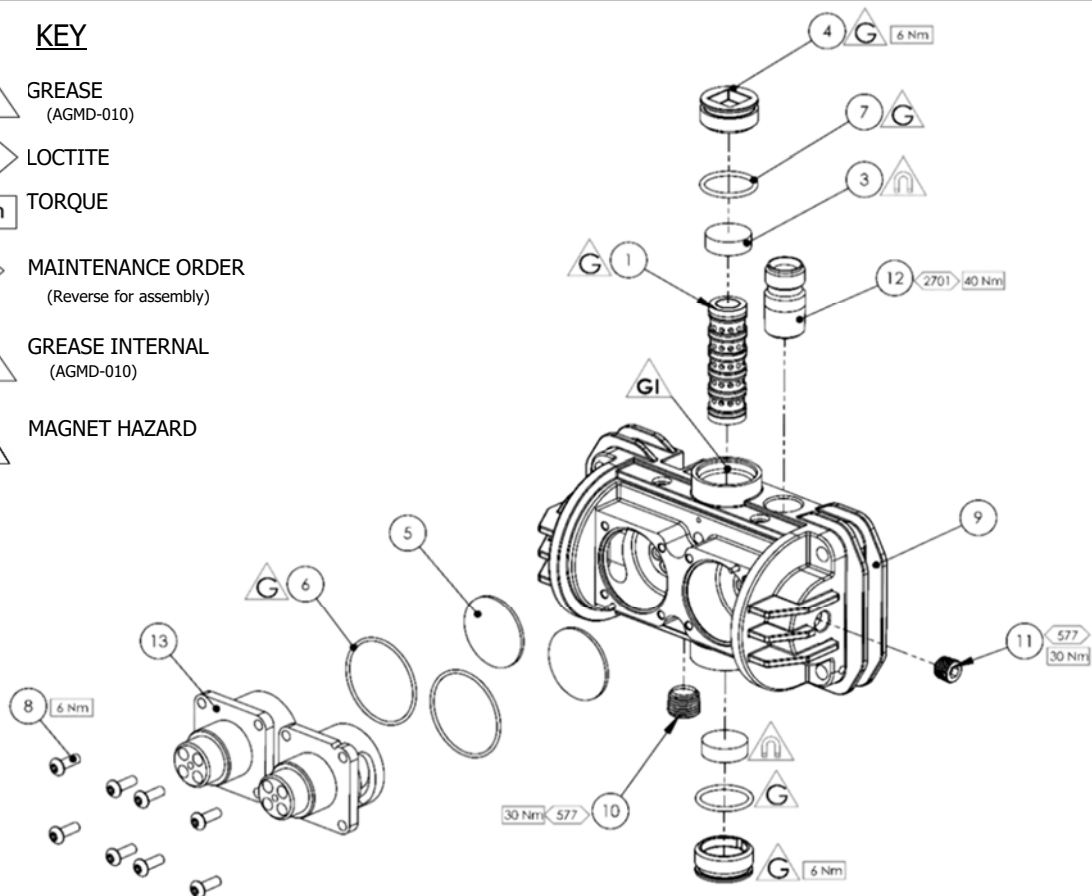
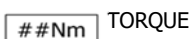

## Fluid Piston Assembly

ITEM	PART NO.	DESCRIPTION	QTY	REMARKS
<b>1</b>	160533	PISTON BALL CHECK SPRING	1	<b>1 2</b>
<b>2</b>	162855	Ø52.07 x 2.62 O-RING	1	<b>1 2</b>
<b>3</b>	162856	Ø41.0 x 1.78 O-RING	1	<b>1 2</b>
<b>4</b>	162857	Ø56.82 x 2.62 O-RING	1	<b>1 2</b>
<b>5</b>	171788	1.375 BALL	1	<b>2</b>
<b>6</b>	192632	INLET SPRING KEEP	1	<b>2</b>
<b>7</b>	193188	SEAT	1	<b>1 2</b>
<b>8</b>	194111	Ø70 FLUID PISTON	1	
<b>9</b>	194113	BALL CAGE	1	

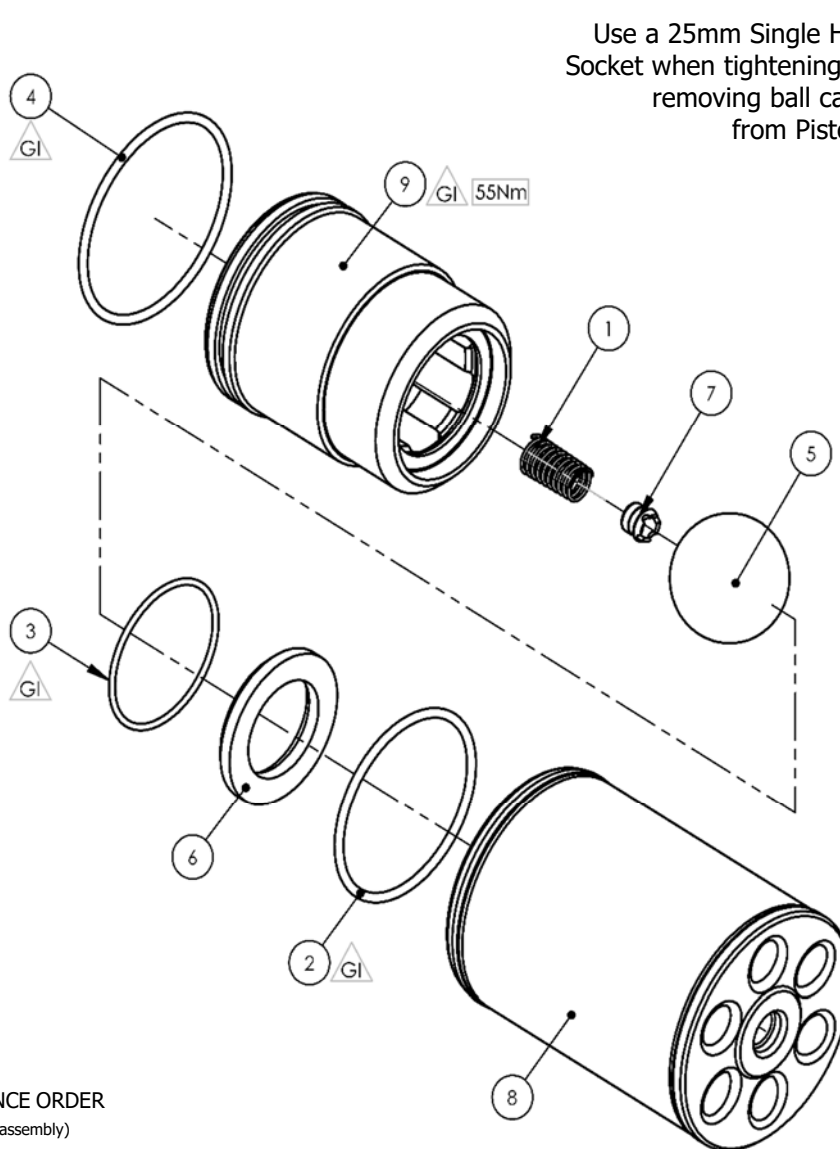

Use a 25mm Single Hex Socket when tightening or removing ball cage from Piston.



**KEY**

- GREASE (AGMD-010)
- LOCTITE
- TORQUE
- MAINTENANCE ORDER (Reverse for assembly)
- GREASE INTERNAL (AGMD-010)

## Fault Finding

Symptom	Possible Cause	Remedy
Pump will not 'Prime'	Air getting into the suction hose/manifold	Check seals and hose connections.
	Worn piston seal.	Replace piston seals.
	Ball checks not seating correctly.	Inspect, clean and/or replace balls and seats.
Pump will not run	No Air or Fluid supply	Check air and fluid supply ball valves and supply hoses.
	Air piston seal worn.	Replace piston seals.
	Pilot valve assemblies inoperable.	Switch/interchange pilot valves to isolate faulty pilot valve and clean/replace.
	Pilot valve assemblies inoperable.	Check clean/replace Air valve.
	QE diaphragm defective.	Check for constant exhaust air when pump is not running. Check/replace QE diaphragms.
	Ball checks not seating correctly.	Inspect, clean and/or replace balls and seats.
Pump runs but has excessive pulsation.	Air getting into fluid line, air supply restricted.	Check seals and hose connections. Check air supply
	Obstructed fluid ball checks.	Remove, clean, and inspect seat, ball, and ball cage. Replace if suspect or worn.

## Fault Finding

Symptom	Possible Cause	Remedy
Pump runs but has excessive pulsation.	Worn air motor piston seals.	Replace air motor piston seal.
	Worn/failed air motor shaft seals.	Disassemble pump as required to replace air motor shaft seals.
	Worn fluid piston seal.	Replace fluid piston seal.
	Air exhaust restricted.	Check QE diaphragms and exhaust outlets.
Paint leaking into detection hose, Air bleeding from vent plug	Bellows seal failure	Replace bellows seal
	Air motor shaft seal leaking	Check air motor shaft seal replace as necessary



## Spares Kits for Maple 15 Pump

KIT No.	PART NO.	DESCRIPTION	QTY.	REMARKS
❶	250790 **	Fluid section seal kit	1	Check main parts list for details of individual kit contents
❷	250736 **	Fluid overhaul kit	1	
❸	250627	Air Motor Seal Kit	1	
❹	250628	Control Valve Kit	1	
#	0115-010037	Poppet Assembly	1	2 off per pump
#	0115-010015	Main Spool & Sleeve Valve Assembly	1	1 off per pump
#	192828	Piston seal	1	2 off per pump
#	192579	Knifed Bellows	1	2 off per pump
# - Recommended spare parts for continually running pumps				

\*\* Note:

Fluid section seal & fluid section overhaul kits contain all the necessary components to service Mark one and two pistons.

Discard components not required.

## Maintenance schedule

Inspection	Operation
Daily	Check for any general fluid or air leakage.
Weekly	Inspect Pump for Correct operation
	Check for any excessive mechanical noise
	Check for excessive fluid pressure pulsation
6 Month Test	Perform a pump stall test to ensure correct operation.
	If pump does not stall check fluid piston seals and ball checks, replace as required.
	If air is escaping through exhaust, check air motor piston seal and quick exhaust diaphragm, replace as required.
12 to 36 Months (Typically 10 million pump cycles dependant on air quality and abrasiveness of the paint used)	Replace air piston seal,
	Replace shaft seals & bearings.
	Inspect and replace if required: Pilot Air Valves & Main Air Valve Parts.
	Replace fluid piston seal,
	Replace Balls, Seats and Bellows.

## Bellows Replacement

ITEM	PART NO.	DESCRIPTION	QTY	REMARKS
<b>1</b>	502769	Bellows Positioning Tool	1	
<b>2</b>	502382	Bellows Assembly Spigot	1	

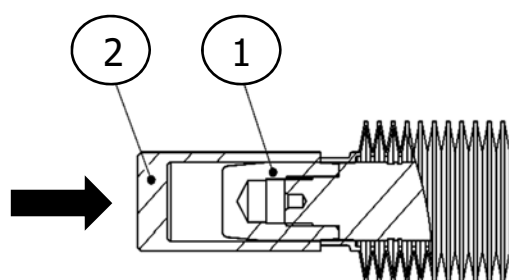

Screw Item No. 2 (assembly spigot) onto the piston shaft

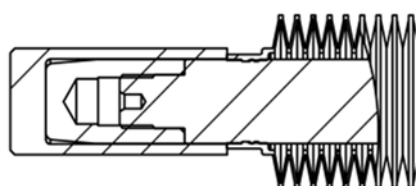

Using Item No. 1, push bellows over spigot until located in groove.

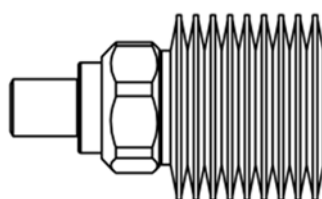

Smear loctite 572 over nose of bellows, thread nut onto bellows ensuring the thread starts squarely. Grip bellows lightly by hand and tighten the nut with a 1" A/F spanner until the nut contacts the bellows shoulder.

## Accessories

ITEM	PART NO.	QTY
<b>192206</b>	1" Sanitary Gasket	
<b>192009</b>	1 & 1 1/2" Heavy duty Sanitary Clamp	
<b>192532</b>	1" Sanitary - 1" BSPT (f) Adapter	
<b>502608</b>	Seal Insertion Tool	For Shaft seal (7)
<b>502769</b>	Bellows Positioning Tool	
<b>AGMD-010</b>	Kluber Isoflex Topas NB 52 Grease	50ml Tube
<b>192779</b>	Exhaust Tube Adapter (1" NB hose)	For piped exhaust
<b>192803</b>	1" Manifold Plug	For piped exhaust
<b>192820</b>	Exhaust Tube Adapter (1.5" NB hose)	For piped exhaust
<b>192821</b>	1" BSP Heavy Duty Mufflers	Recommended for high pump pressures and cycle rates

## WARRANTY POLICY

This product is covered by Carlisle Fluid Technologies' materials and workmanship limited warranty. The use of any parts or accessories, from a source other than Carlisle Fluid Technologies, will void all warranties. Failure to reasonably follow any maintenance guidance provided, may invalidate any warranty.

For specific warranty information please contact Carlisle Fluid Technologies.

Carlisle Fluid Technologies is a global leader in innovative finishing technologies. Carlisle Fluid Technologies reserves the right to modify equipment specifications without prior notice.

DeVilbiss®, Ransburg®, MS®, BGK®, and Binks® are registered trademarks of Carlisle Fluid Technologies, Inc.

© 2019 Carlisle Fluid Technologies, Inc.

All rights reserved.

For technical assistance or to locate an authorised distributor, contact one of our international sales and customer support locations below.

<b>Region</b>	<b>Industrial / Automotive</b>	<b>Automotive Refinishing</b>
<b>Americas</b>	Tel: 1-888-992-4657 Fax: 1-888-246-5732	Tel: 1-800-445-3988 Fax: 1-800-445-6643
<b>Europe, Africa, Middle East, India</b>	Tel: +44 (0)1202 571 111 Fax: +44 (0)1202 573 488	
<b>China</b>	Tel: +8621-3373 0108 Fax: +8621-3373 0308	
<b>Japan</b>	Tel: +81 45 785 6421 Fax: +81 45 785 6517	
<b>Australia</b>	Tel: +61 (0) 2 8525 7555 Fax: +61 (0) 2 8525 7575	

For the latest information about our products, visit [www.carlisleft.com](http://www.carlisleft.com)



SOLUTIONS FOR YOUR WORLD