

# SALES AND ENGINEERING DATA



## LM2305A-( )-B TWO - BALL PUMP

RATIO: **5:1**  
SERIES:

FLUID PSIG: **0 - 750**  
RANGE:

RELEASED: 12-27-04  
REVISED: 11-30-17  
(REV: D) S-1356

### DIMENSIONAL DATA

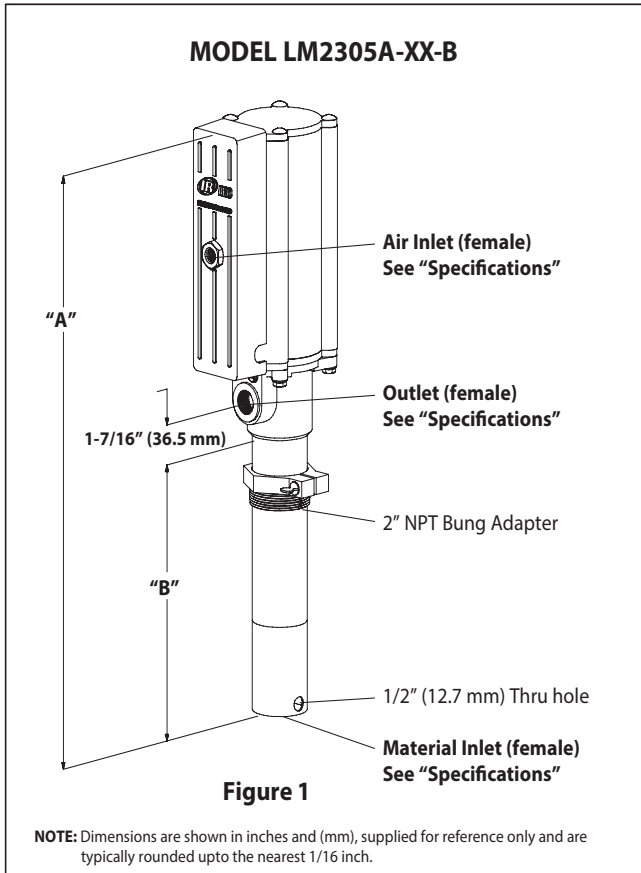

MODEL	"A" (mm)	"B" (mm)	WEIGHT (kg)
LM2305A-1X-B	21" (533.4)	9-3/4" (247.7)	15.75 (7.14)
LM2305A-2X-B	31-1/2" (800.1)	20-1/4" (514.4)	XXX (XXX)
LM2305A-3X-B	41-1/4" (1047.8)	30" (762)	24.3 (11.02)
LM2305A-4X-B	51" (1295.4)	39-3/4" (1009.7)	28.5 (12.93)
LM2305A-5X-B	58-5/8" (1489.1)	47-3/8" (1203.3)	31.7 (14.38)

### SPECIFICATIONS

#### CONSTRUCTION

Model Series	LM2305A-XX-B
Pump Type	Air Operated, Two-Ball, Double Acting Oil Pump
Ratio	5:1
Air Motor Diameter	3" (7.62 cm)
Stroke	3" (7.62 cm)
Air Inlet (female)	
LM2305A-X1-B	1/4 - 18 NPTF - 1
LM2305A-X2-B	Rp 1/4 (1/4 - 19 BSP Parallel)
Material Inlet (female)	
LM2305A-X1-B	1-1/2 - 11-1/2 NPTF - 1
LM2305A-X2-B	Rp 1-1/2 (1-1/2 - 11 BSP Parallel)
Material Outlet (female)	
LM2305A-X1-B	1/2 - 14 NPTF - 1
LM2305A-X2-B	Rp 1/2 (1/2 - 14 BSP Parallel)
Pump Rebuild Kit	637226

#### MATERIALS OF CONSTRUCTION

Outlet Body	Steel
Cylinder	Aluminium
Plunger	Steel
Upper Packing	Polyurethane
Lower Packing	Polyurethane
Upper Seat	Steel
Lower Seat	Steel
Upper Ball	Steel
Lower Ball	Steel
Inlet Body	Steel

#### PERFORMANCE

Air Inlet Pressure Range	0 - 150 psig (0 - 10.3 bar)
Fluid Pressure Range	0 - 750 psig (0 - 51.7 bar)
Maximum Rec'd Cycles / Minute	120
Displacement Per Cycle @ 100 psig	8.3 in <sup>3</sup> (136.0 cc)
Cycles Per Gallon	28
Flow @ 120 Cycles / Minute	4.3 gpm (16.3 lpm)
Noise Level @ 100 psig	85 dB(A) ①

① The pump sound pressure level has been updated to an Equivalent Continuous Sound Level (LAeq) to meet the intent of ANSI S1. 13-1971, CAGI-PNEUROPS5.1 using four microphone locations.

#### ACCESSORIES:

- 61113 Wall Mount Bracket
- 66073-1 Air Line Connection Kit

## PERFORMANCE CURVES

**PERFORMANCE BASED ON 30wt. OIL (100 cSt) AT 40° C TEMPERATURE**

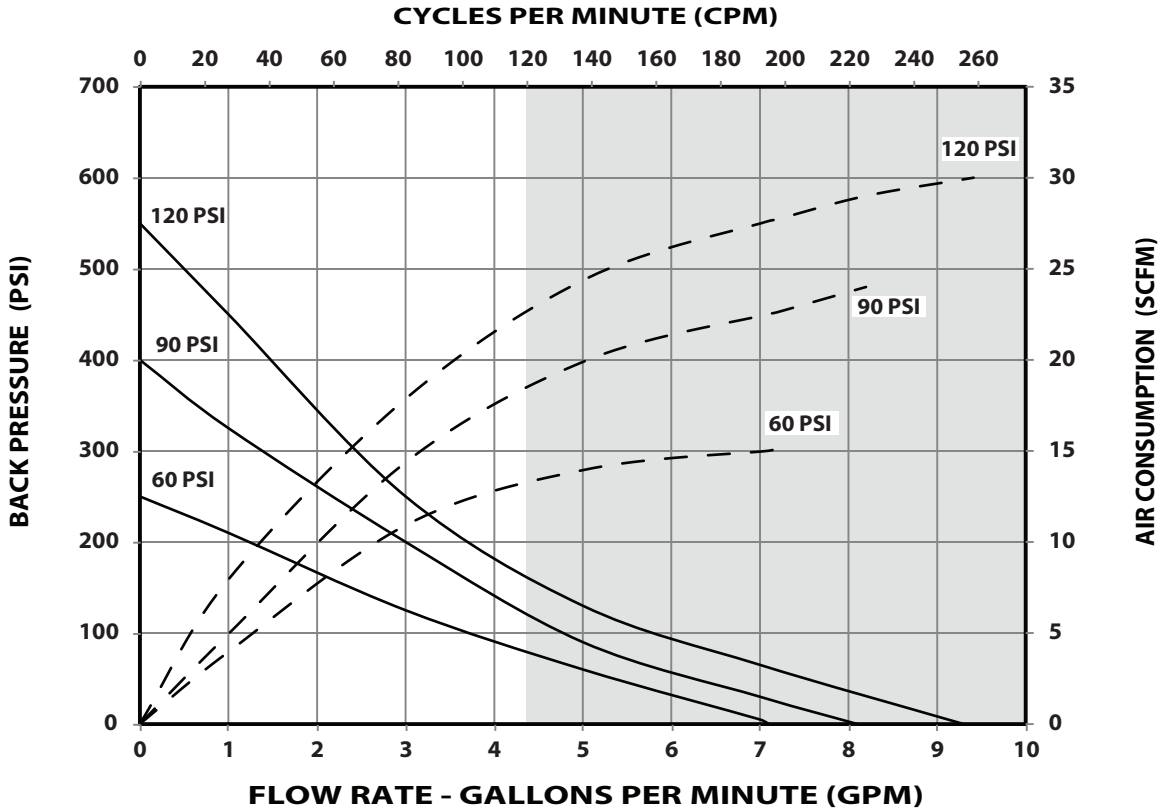

**NOTE : NON SHADED AREA OF THE GRAPH REPRESENTS RECOMMENDED OPERATING RANGE**

**PERFORMANCE BASED ON 30wt. OIL (100 cSt) AT 40° C TEMPERATURE**

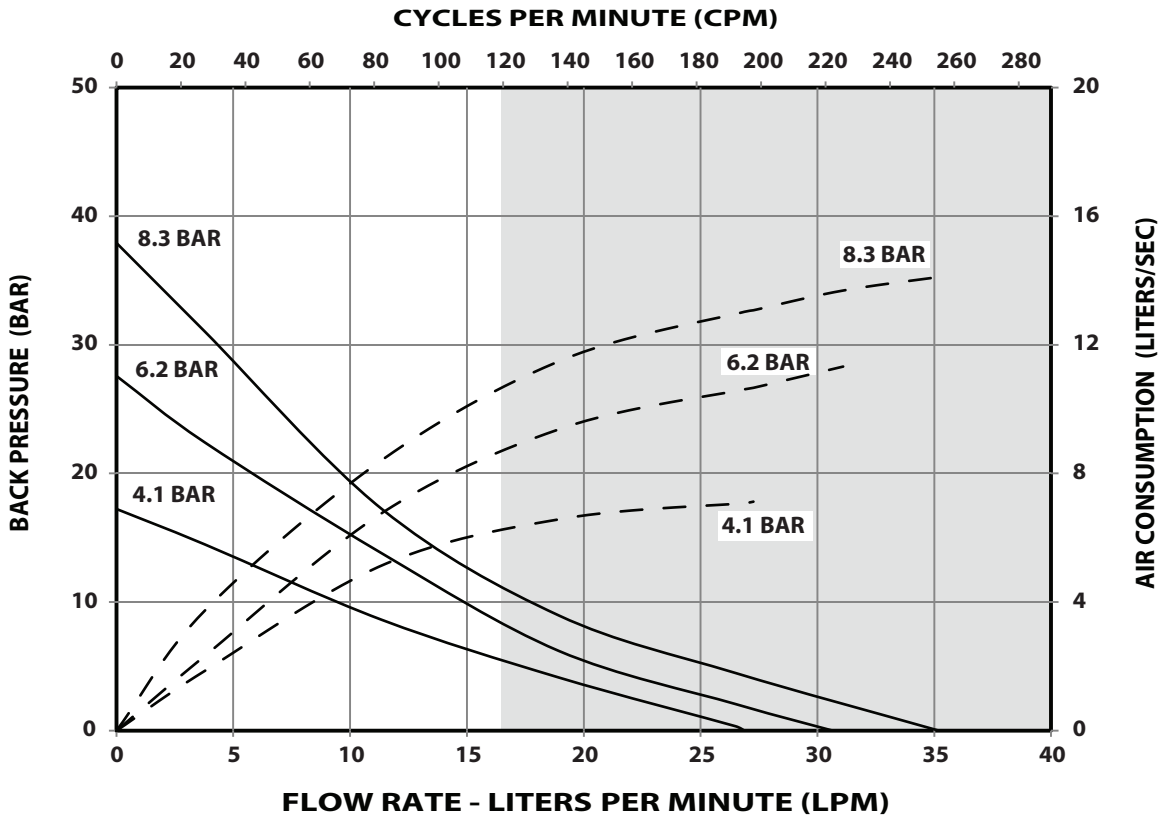

**NOTE : NON SHADED AREA OF THE GRAPH REPRESENTS RECOMMENDED OPERATING RANGE**