



**45530128**  
Edition 1  
May 2007

# Electric Screwdrivers

EL 24V DC Series

---

## Parts Information



Save These Instructions

 **Ingersoll Rand**

Models EL0410B, EL0410BC, EL1007B and EL1007BC Electric Screwdriver Exploded Diagram

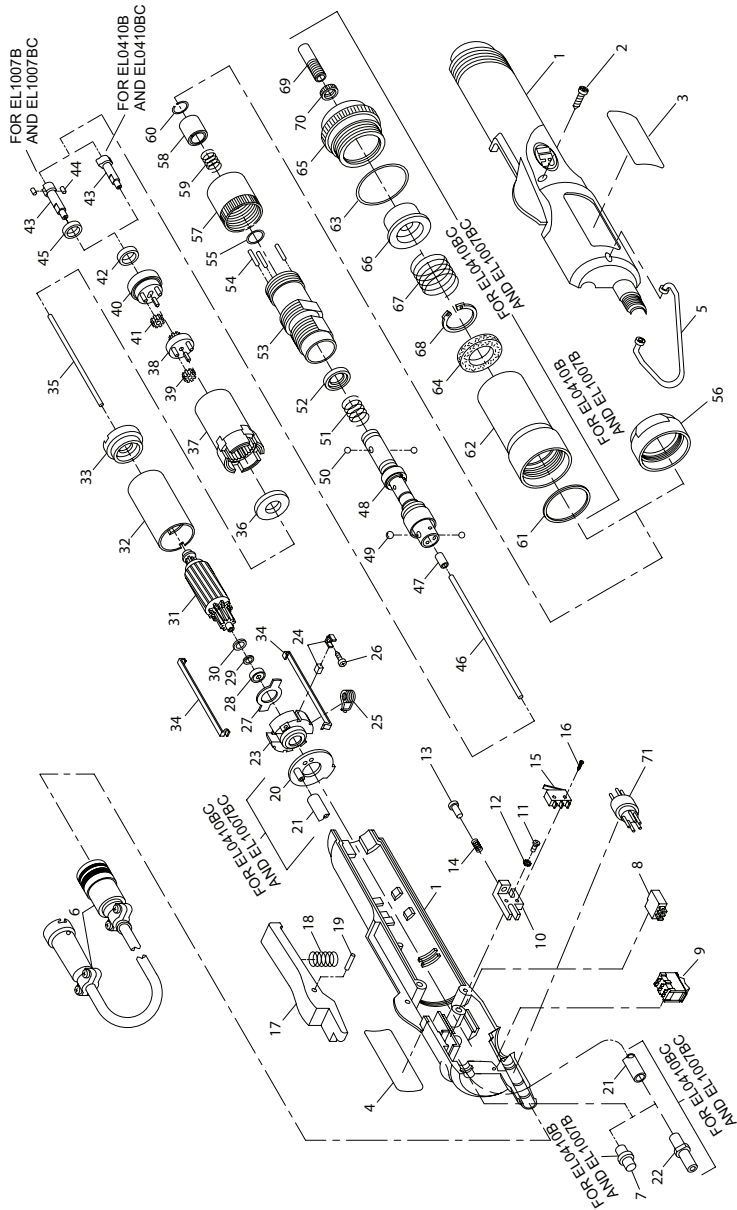

**Models EL0410B, EL0410BC, EL1007B and EL1007BC Electric Screwdriver Parts List**

Item	Part Description	Part Number	Item	Part Description	Part Number
	Housing Package		38	Gear Head Assembly	
	for EL0410B	EL0410B-A40		for EL0410B and EL0410BC	EL0410B-216
	for EL1007B	EL1007B-A40	for EL1007B and EL1007BC	EL1007B-216	
	for EL0410BC	EL0410BC-A40	39	Gear Head Planet Gear (3)	
for EL1007BC	EL1007BC-A40	for EL0410B and EL0410BC		EL0410B-10	
1	Housing	----		for EL1007B and EL1007BC	EL1007B-10
2	Housing Screw	----	40	Spindle Assembly	EL0410B-108
3	Nameplate		41	Spindle Planet Gear (3)	
	for EL0410B	EL0410B-301		for EL0410B and EL0410BC	EL0109B-9
	for EL1007B	EL1007B-301		for EL1007B and EL1007BC	EL1007B-9
	for EL0410BC	EL0410BC-301	42	Thrust Washer	EL0410B-109
	for EL1007BC	EL1007BC-301	43	Cam	
4	Warning Label	EL0109B-99		for EL0410B and EL0410BC	EL0410B-581
5	Suspension Bail	EL0109B-365		for EL1007B and EL1007BC	EL1007B-581
6	Power Cord Assembly	EL0109B-239	44	Cam Pin (2) (for EL1007B and EL1007BC)	EL1007B-587
7	Housing Bushing	EL0109B-465	45	Cam Collar (for EL1007B and EL1007BC)	EL1007B-588
8	Trigger Switch	EL0109B-222	46	Push Rod (1.650" long)	EL0109B-435
9	Reverse Switch	EL0109B-329	47	Cam Guide Sleeve	EL410B-408
10	Switch Plate	EL0109B-221	48	Bit Holder Assembly	EL1007B-586
11	Switch Plate Screw (2)	EL0109B-226	49	Cam Guide Ball (2)	EL1007B-933
12	Switch Plate Screw Lock Washer (2)	EL0109B-227	50	Bit Retaining Ball (2) (.094" dia.)	ROO0B-263
13	Plunger	EL0109B-593	51	Clutch Spring	
14	Plunger Spring	EL0109B-595		for EL0410B and EL0410BC	EL0410B-583
15	Brake Switch	EL0109B-223		for EL1007B and EL1007BC	EL1007B-583
16	Microswitch Screw (2)	EL0109B-224	52	Clutch Spring Plate	EL0410B-623
17	Trigger	EL0109B-93	53	Clutch Housing	EL0410B-580
18	Trigger Spring	EL0109B-274	54	Clutch Adjusting Pin (3)	
19	Trigger Pin	EL0109B-275		for EL0410B and EL0410BC	EL0410B-416
20	Shield Plate (for EL0410BC and EL1007BC)	EL0410BC-42		for EL1007B and EL1007BC	EL1007B-416
21	Vacuum Tube (for EL0410BC and EL1007BC)	EL0410BC-43	55	Bit Retainer Retaining Ring	EP4007N-584
22	Vacuum Tube Nozzle (for EL0410BC and EL1007BC)	EL0410BC-44	56	Coupling	EL0109B-125
			57	Clutch Adjusting Ring	EL0109B-582
	Motor Assembly		58	Bit Retainer Sleeve	EL0410B-930
			for EL0410B and EL0410BC	EL0410B-A53	59
	for EL1007B and EL1007BC	EL1007B-A53	60	Bit Retainer Retaining Ring (front)	EP4007N-683
23	Rear End Plate	EL0109B-12	61	Packing Ring (for EL0410BC and EL1007BC)	EL0410BC-45
24	Brush Assembly (2)	----	62	Nose Collar (for EL0410BC and EL1007BC)	EL0410BC-46
25	Brush Spring	EL0109B-16	63	O-ring (for EL0410BC and EL1007BC)	EL0410BC-47
26	Brush Screw (2)	----	64	Filter (for EL0410BC and EL1007BC)	EL0410BC-48
27	Motor Plate	EL0109B-13	65	Front Cap (for EL0410BC and EL10007BC)	EL0410BC-49
28	Rear Armature Bearing	EL0109B-22	66	Sleeve Holder (for EL0410BC and EL10007BC)	EL0410BC-50
29	Shim (2) (.238" O.D. X .020" thick)	EL0109B-56	67	Holder Spring (for EL0410BC and EL10007BC)	EL0410BC-51
30	Shim (.375" O.D. X .015" thick)	EL0109B-55	68	Holder Retaining Ring (for EL0410BC and EL10007BC)	EL0410BC-52
31	Armature			Vacuum Sleeve (for EL0410BC and EL10007BC)	EL0410BC-53
	for EL0410B and EL0410BC	EL0410B-53	70	Vacuum Sleeve Lockout (for EL0410BC and EL10007BC)	EL0410BC-54
	for EL1007B and EL1007BC	EL1007B-53	71	Insulator	EL0109B-330
32	Field	EL0109B-54	*	Switch Adjusting Gauge	EL0410B-SG
33	Front End Plate	EL0109B-11	*	Gear Case Fixture	EL0410B-J37
34	Motor Assembly Spring (2)	EL0109B-98	*	Brush Package (10 pieces)	EL0109B-BP
35	Push Rod (1.403" long)	EL0109B-436	*	Hardware Package (includes illustrated items 2[3], 11[2], 12[2], 13, 16[2], 18, 19, 25, 26[2], 34[2], and 60	EL0109B-HP
36	Motor Clamp Spacer	EL0109B-207			
37	Gear Case				
	for EL0410B and EL0410BC	EL0410B-37			
	for EL1007B and EL1007BC	EL1007B-37			

\* Not Illustrated

# Model EL0109B Electric Screwdriver Exploded Diagram

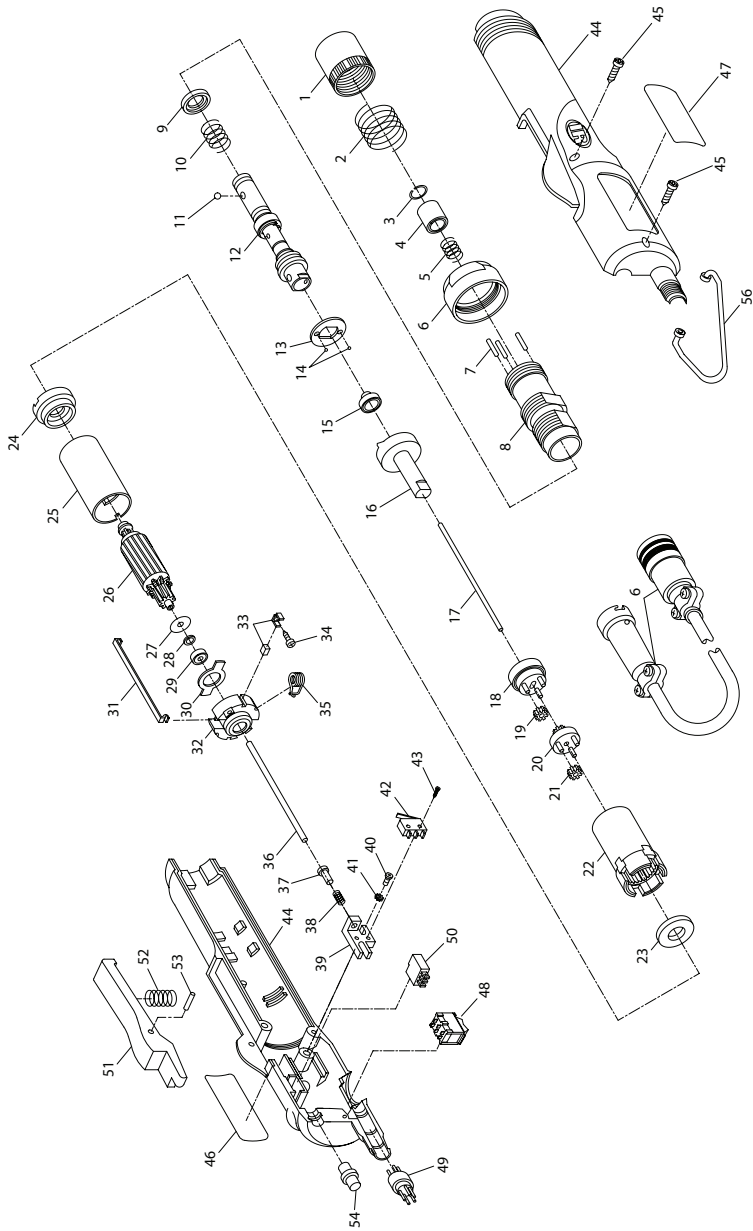

(Dwg. TPA1501)

## Model EL0109B Electric Screwdriver Parts List

Item	Part Description	Part Number	Item	Part Description	Part Number
1	Clutch Adjusting Ring	EL0109B-582	32	Rear End Plate	EL0109B-12
2	Bit Retainer Spring	EL0109B-931	-	Brush Package	EL0109B-BP
3	Bit Retainer Retaining Ring	EP4007N-683	33	Brush Assembly (2) (pkg. of 10)	----
4	Bit Retainer Sleeve	EP4007N-930	34	Brush Screw (2)	----
5	Bit Retainer Sleeve Spring	EP4007N-931	35	Brush Spring	EL0109B-16
6	Coupling	EL0109B-125	36	Push Rod (1.403" long)	EL0109B-436
7	Clutch Adjusting Pin (3)	EP4007N-416	37	Plunger	EL0109B-593
8	Clutch Housing	EL0109B-580	38	Plunger Spring	EL0109B-595
9	Clutch Spring Plate	EL0109B-623	39	Shutoff Switch Plate	EL0109B-221
10	Clutch Spring	EL0109B-583	40	Switch Plate Screw (2)	----
11	Bit Retaining Ball (2 mm dia.)	EL0109M-932	41	Switch Plate Screw Lock Washer (2)	----
12	Bit Holder Assembly (2)	EL0109B-586	42	Brake Microswitch	EL0109B-223
13	Cam Guide	E10109B-681	43	Microswitch Screw (2)	----
14	Cam Guide Ball (2) (3 mm dia.)	EL0109B-933	-	Housing Package	SLE01-9-A40
15	Cam Guide Sleeve Assembly	EL0109B-408	44	Housing	----
16	Cam	EL0109B-581	45	Housing Screw (3)	----
17	Push Rod (1.650" long)	EL0109B-435	46	Warning Label	EL0109B-99
18	Spindle Assembly	EL0109B-108	47	Nameplate	EL0109B-301
19	Spindle Planet Gear (3)	EL0109B-9	48	Reverse Switch	EL0109B-329
20	Gear Head Assembly	EL0109B-216	49	Insulator	EL0109B-330
21	Gear Head Planet Gear (3)	EL0109B-10	50	Triggerswitch	EL0109B-222
22	Gear Case	EL0109B-37	51	Trigger	EL0109B-93
23	Motor Clamp Spacer	EL0109B-207	52	Trigger Spring	EL0109B-274
-	Motor Assembly	EL0109B-A53	53	Trigger Pin	EL0109B-275
24	Front End Plate	EL0109B-11	54	Housing Bushing	EL0109B-465
25	Field	EL0109B-54	55	Power Cord Assembly	EL0109B-239
26	Armature	EL0109B-53	56	Suspension Bail	EL0109B-365
27	Shim (.375" O.D. X .015 thick)	EL0109B-55	*	Switch Adjusting Gauge	EL0410B-SG
28	Shim (.238" O.D. X .020 thick)	EL0109B-56	*	Gear Case Fixture	EL0410B-J37
29	Rear Armature Bearing	EL0109B-22	*	Hardware Package (includes parts 3, 11, 31[2], 34[2], 35, 37, 40[2], 41[2], 43[2], 45[3], 52, and 53)	EL0109B-HP
30	Plate	EL0109B-13			
31	Motor Assembly Spring (2)	EL0109B-98			

\* Not Illustrated

---

## **Parts and Maintenance**

When the life of the tool has expired, it is recommended that the tool be disassembled, degreased and parts be separated by material so that they can be recycled.

Tool repair and maintenance should only be carried out by an authorized Service Center.

Refer all communications to the nearest **Ingersoll Rand** Office or Distributor.

---

## **Related Documentation**

For additional information refer to:

Product Safety Information Manual 16573685.

Product Information Manual 45527595.

Maintenance Information Manual 45530136.

Manuals can be downloaded from [www.irtools.com](http://www.irtools.com).

**Notes:**

---

[www.irttools.com](http://www.irttools.com)

© 2007 *Ingersoll Rand* Company

